

TectoCell Standard Plus 80 cold rooms and deep-freeze rooms
TectoCell Standard Plus 100 cold rooms and deep-freeze rooms
TectoCell Standard Plus 120 deep-freeze room
TectoCell Standard Plus 150 deep-freeze room



Contents

1	User Guide	3
1.1	Target group.....	3
1.2	Structure of the operating instructions	3
1.3	Related documents	3
1.4	Safekeeping.....	3
1.5	Symbols on the product	4
2	Safety and dangers	4
2.1	Intended use	5
2.2	Foreseeable Misuse.....	5
3	Transport	5
3.1	Delivery	5
4	Assembly	6
4.1	Installation conditions.....	6
4.2	Before installation	6
4.3	Level floor	7
4.4	Assembling a mounting frame (without floor).....	7
4.5	Assembling room elements 8	
4.6	Assembling floor elements	8
4.7	Seal operating apertures in the cam locks in the floor elements	9
4.8	Assembling wall elements.....	9
4.9	Assembling partition wall of combination rooms without tongue and groove system.....	10
4.10	Mounting the door.....	10
4.11	Mounting ceiling elements.....	10
4.12	Seal operating apertures in the cam locks in the wall and ceiling elements.....	11
4.13	Mount doorsill (for rooms with floor elements)	11
4.14	Remove transport securing plates	11
4.15	Adjusting the door.....	12
4.16	Light test	12
4.17	Attaching the cover caps.....	12
4.18	Fastening the striker	12
4.19	Mechanical work on the door or porthole	13
4.20	Rearranging the luminaries.....	13
5	Sealing of openings and cut edges	13
6	Electrical connections	14
7	Commissioning	15
7.1	Commissioning the cold room.....	15
8	Cleaning	15
9	Decommissioning	15
10	Technical data	15
10.1	Permissible loading on floor elements.....	16
11	Maintenance	16
12	Disposal	16
13	Standards and laws	16
14	Warranty	16
15	Wiring diagram for revolving door SKI	17
16	Wiring diagram for revolving door SKI	18
17	Wiring diagram for porthole	19

1 User Guide

All important information for operation and control is summarized in these operating instructions.

Read the operating instructions completely and only use the product after you have first understood the operating instructions.

If you have any questions, please contact your Viessmann specialist partner. You will find the current address on the back page.

1.1 Target group

These instructions are aimed exclusively at authorized specialists.

- Electrical work to be performed exclusively by qualified electricians.
- Initial commissioning is to be performed exclusively by the manufacturer or by a specialist designated and authorized by the manufacturer.

1.2 Structure of the operating instructions

1.2.1 Warnings



Structure of the warnings

Warnings are structured as follows:

 SIGNAL WORD!	Source of danger! Consequences of non-compliance. ▶ Measure to avoid the danger.

Gradation of the warnings

Warnings differ according to the type of danger as follows:

 DANGER!	Warns against an imminent threat of danger, which will lead to death or serious injuries if it is not avoided.
 WARNING!	Warns against a possibly dangerous situation, which will lead to death or serious injuries if it is not avoided.
 CAUTION!	Warns against a possibly dangerous situation, which will lead to moderate or minor injuries if it is not avoided.
NOTE	Warns against a possibly dangerous situation, which will lead to damage to property or the environment if it is not avoided.

Tips, notes, and recommendations

- ⓘ Gives the user tips, notes, or recommendations on using the product efficiently.

1.2.2 Additional symbols

Handling instructions

Handling instructions ask you to carry out an operation or a work step. Handling instructions should always be carried out individually and in the specified sequence.

Structure of the handling instructions:

- Instructions for an operation.

Results if required.

Lists

Structure of the unnumbered lists:

- List level 1
 - List level 2

Structure of the numbered lists:

1. List level 1
 - 1.1 List level 2

1.3 Related documents

Please also observe the additional documents provided (such as the delivery documents) and relevant standards and laws follow the safe and correct use of the device.

1.4 Safekeeping

Keep the Operating Manual, including the related documents, handy in the vicinity of the device.

1.5 Symbols on the product

Türelement für Kühlzelle Panneau de Porte Door element		VISSMANN
Herstell-Nr. Serial number	7757669 7757669600178108	
Typ/Type	TE M 1200 x 1950 x VL 80	
Herstelljahr Année de construction Year of construction	 2016	
Art der Ausführung Version	LW 800 x 1800 DIN rts T0 ohz	
Nennspannung Tension nominale Nominal voltage	AC 230V ~	
Nennaufnahme Puissance nominale absorbée Rated power consumption	10 Watt	
Max. Nennleistung LED Leuchte Max. puissance nominale de la lampe LED Max. power rating of the LED lamp	10 Watt	
Viessmann Kältetechnik GmbH Schlüsselstr. 100 D-95530 Hof / Saale Tel.: +49 9281 814 - 0 www.viessmann.de/kuehlssysteme	  	
		

The adjacent graphic shows an exemplary depiction

Standard-Boden:
- nur feucht auswischen. Nicht geeignet für stehendes Wasser oder Strahlwasser!
Warmenboden:
- feucht auswischen. Nur kurzzeitig für stehendes oder Strahlwasser geeignet!
Decke, Wände ohne und mit Wanddämmung, Elemente mit elektrischen Bauteilen (z.B. Türstock) und Aggregat:
- innen und außen nicht mit Wasser abspritzen!
Elemente mit eingeschäumten elektrischen Bauteilen (z.B. Türelement):
- mechanische Arbeiten nur nach Montageanleitung vornehmen!

Standard floor:
- only wipe with a moist cloth. Not suited for stagnant water or jet water!
Vat shaped floor:
- wipe with a moist cloth.
- Only temporarily suited for stagnant water or jet water!

Ceiling, walls without and with overlapping joints, elements with electrical components (e.g. doorframe) and refrigeration units:
- Do not hose down with water, neither inside nor outside!

Elements with foam-packed electrical components (e.g. door element):
- mechanical work only to be undertaken in accordance with assembly instructions!

Soil standard:
- Essuyez la surface avec un chiffon ou une éponge humide. Le sol ne doit pas être arrosé ou recevoir des projections d'eau.

Basin:
- Essuyez la surface avec un chiffon ou une éponge humide. Ne pas exposer longtemps à des arrosages ou des projections d'eau.

Piafond, cloisons avec ou sans revêtement, éléments comportant des composants électriques (par exemple dormant de la porte) et groupe:
- Pas de projections d'eau à l'intérieur ou à l'extérieur.

Éléments avec composants électriques noyés dans la mousse (par exemple battant de porte):
- Les interventions mécaniques doivent s'effectuer selon la notice de montage.

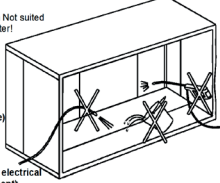

00035672-03

The adjacent graphic shows an exemplary depiction

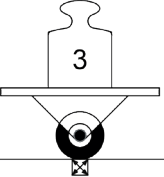

3

1-4 cm² 1000 N
>4 cm² 4000N

Lastfläche/Rad
surface de contact/roues
contact surface/wheel

50.000 N/m² Zulässige Flächenlast/m²
Charge max. admissible au m²
Permissible area load/m²

Rutschhemmung
Bewertungsgruppe

R11

5538304
EN 1.5

The adjacent graphic shows an exemplary depiction

Notöffnung!
Emergency exit / Sortie de secours



Öffnen
Open
Ouvrir

5126997

The adjacent graphic shows an exemplary depiction



Arbeiten zum Netzan-
schluss und Schutz-
maßnahmen sind von
der Fachfirma gemäß
IEC 364 und den
örtlichen Vorschriften
und Anschlussbedingungen des jeweili-
gen Energieversorgungsunternehmens
auszuführen!

5023024

2 Safety and dangers

⚠ DANGER! **Danger to life as a result of strong magnetic fields!**

- ▶ Make sure that no persons with active medical equipment (e.g. pacemakers) are in the vicinity of the magnetic fields.

⚠ DANGER! **Risk of death due to electric shock!**

- ▶ Before any work on TectoCell cold rooms and deep-freezing rooms, pull the power plug or shut off the mains power and secure it to prevent it from being turned back on.
- ▶ Observe country-specific standards and guidelines before working on electrical equipment.

⚠ DANGER! **Risk of death due to electric shock!**

- ▶ Do not conduct any mechanical work (such as drilling or sawing) on the inside or outside of the door or porthole (see Chap. "4.19 Mechanical work on the door or porthole" on page 13).

NOTE **Damage from impermissible bearing load!**

- ▶ Prevent additional force (e.g. from snow and wind loads) from being exerted.
- ▶ Ensure sufficient reinforcement or structural support on-site before entering (e.g. when installing a new ceiling unit or other structures).

NOTE **Corrosion from installing unalloyed steel!**

- ▶ Immediately remove corrosion from unalloyed steel.
- ▶ Clean stainless steel surfaces thoroughly after contact with unalloyed stainless steel.

NOTE **Damage to the door!**

- ▶ If no door stop has been installed, please make sure to carefully open the door in order to prevent damages to the door or the wall.

NOTE **Damage from defective cold rooms and deep-freezing rooms!**

- ▶ Ensure that only trained qualified personnel operate the TectoColdrooms and deep-freezing rooms.
- ▶ Use TectoCell cold rooms and deep-freezing rooms exclusively in original condition without unauthorized modifications and in technically perfect condition.

- Follow Installation and Operating Instructions.
- Have mounting, maintenance, cleaning, and repair work performed exclusively by trained specialists.

2.1 Intended use

Use the TectoCell cold rooms and deep-freezing rooms exclusively for cooling suitable refrigerated products.

Use TectoCell cold rooms and deep-freezing rooms exclusively for:

- commercial purposes
- for the specified temperature range
- for stationary use

2.2 Foreseeable Misuse

Do not use TectoCell cold rooms and deep-freezing rooms for mobile uses. Do not install TectoCell cold rooms and deep-freezing rooms in areas exposed to the effects of weathering. Any use which does not comply with the conditions of use discussed during the sales process is deemed to be misuse.

3 Transport

- Only carry room elements from the bottom to prevent panels from separating.

3.1 Delivery

Delivery condition:

- Delivery in individual packaging units
- Individual elements must be marked with stickers or numbers.
- The door panel (single-leaf) is pre-mounted in the door frame.
- The following are built into the door frame:
 - Control panel
 - LED Moisture-proof lamp with integrated junction box
 - Junction box only for option without lamp
- Mounting accessories are packaged separately.

The control panel contains:

- Light switch
- Thermometer
- Pressure equalisation valve
- Door frame heating and pressure compensation valve (optional for wall thickness 80)

3.1.1 Unpacking

Before and during the unpacking:

- comply with the safety and environmental regulations at the installation site.
- Check TectoCell cold rooms and deep-freezing rooms for transport damages with a visual inspection.
- In order to process warranty claims, report faults (with photos, for instance) to the manufacturer and indicate the manufacturer number and type designation.
- "Provisions in the event of damage" must be observed!
- Observe the "General conditions for transport damage and hidden transport damage".
- Check packaging material for loose parts after unpacking.
- Dispose of packaging material in an environmentally compatible way according to local regulations.

4 Assembly

⚠ DANGER!	<p>Risk of death due to electric shock!</p> <ul style="list-style-type: none"> ▶ Do not conduct any mechanical work (such as drilling or sawing) on the inside or outside of the door or porthole (see Chap. "4.19 Mechanical work on the door or porthole" on page 13).
------------------	--

NOTE	<p>Damage due to improper handling!</p> <ul style="list-style-type: none"> ▶ Ensure that the seal profiles of the elements are not damaged.
-------------	---

NOTE	<p>Damage due to improper transport!</p> <ul style="list-style-type: none"> ▶ Only carry room elements from the bottom to prevent panels from separating.
-------------	---

NOTE	<p>Damage due to improper mounting!</p> <ul style="list-style-type: none"> ▶ Make sure that room elements are correctly mounted after assembly.
-------------	---

NOTE	<p>Damage due to improper mounting!</p> <ul style="list-style-type: none"> ▶ Make sure that all preparatory work for mounting units to the elements. ▶ Observe unit instructions.
-------------	--

4.1 Installation conditions

NOTE	<p>Damage due to condensation water!</p> <ul style="list-style-type: none"> ▶ Make sure that the installation room is sufficiently ventilated. ▶ Make sure that all necessary distances are complied with.
-------------	---

Conditions for installation space

- Do not install TectoCell cold rooms and deep-freezing rooms near heat sources.
- Avoid direct sunlight.
- Make sure that the installation space is sufficiently ventilated in order to discharge any heat that builds up.
- Distance from TectoCell cold rooms and deep-freezing rooms to building wall and ceiling:
 - Room temperature in positive range: at least 50 mm
 - Room temperature in negative range: at least 100 mm
 - The distance from the room to the wall must be ensured with suitable spacers, since the room's position may slip depending on the load it is under!
- Observe specifications on the necessary clearance above the TectoCell cold rooms and deep-freezing rooms in the operating instructions of the unit in question.
- Observe a suitable installation height for floor prop designs and add to it if necessary.

Conditions for outdoor installation

- Make sure that the TectoCell cold rooms and deep-freezing rooms is not exposed to the effects of weathering (snow loads, rainwater, wind pressure, etc.).
- Make sure that local and on-site construction measures to protect from the effects of weathering have been completed before installing the Tecto cold rooms and deep-freezing rooms.
- Observe national and local rules on work safety and accident prevention measures.
- Observe local regulations on operation and maintenance.

4.2 Before installation

- Make sure that the floor is level.
- Level uneven floor (siehe Kap. „4.3 Boden ausgleichen“ auf Seite 7).
- Contact Viessmann if it is not possible to comply with national and local regulations.
- Carefully remove the elements and accessories.
- Pre-sort the elements and accessories.
- Draw the footprint of the room on the installation floor using a suitable implement.

4.3 Level floor

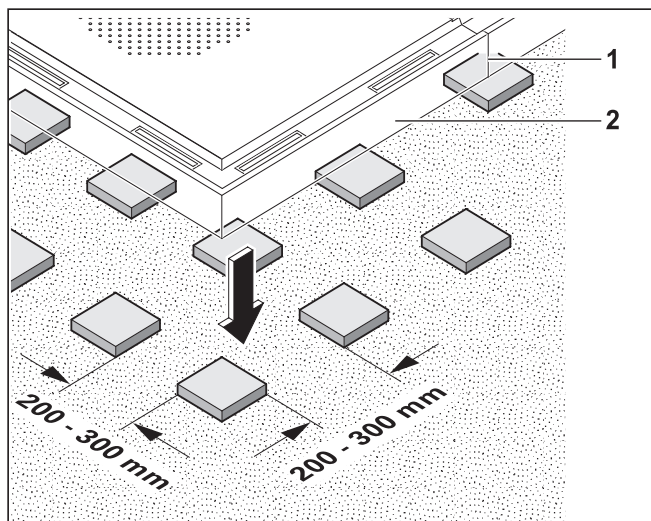

4.3.1 Room with floor ventilation

ⓘ Rooms with floor ventilation: Room temperature below -5°C .

- ➔ If the floor on site is not even or not horizontal, level the height of the bottom ventilation panel:
 - with adjustment plates
- ➔ Lay bottom ventilation panel loosely at distances of 200–300 mm (clear space).
- ➔ Begin levelling at the highest point.
- ➔ Make sure that the element joints (1) are centred during assembly and that the outsides of the elements (2) are lying with their full surfaces on the bottom ventilation panels.

4.3.2 Room without floor ventilation

- ➔ If the floor on-site is uneven or not horizontal, adjust its height with adjustment plates.

4.4 Assembling a mounting frame (without floor)

NOTE

Damage due to improper mounting!

- ▶ Before drilling, make sure that any moisture barriers which may be laid on-site in screed are not damaged.
- ▶ Make sure that no dowel holes are under the cam locks of the elements.
- ▶ Make sure that the sealing lip is correctly seated on the floor on-site.

ⓘ Thanks to their special design, the plastic U-profiles seal all the way down to the floor after assembly.

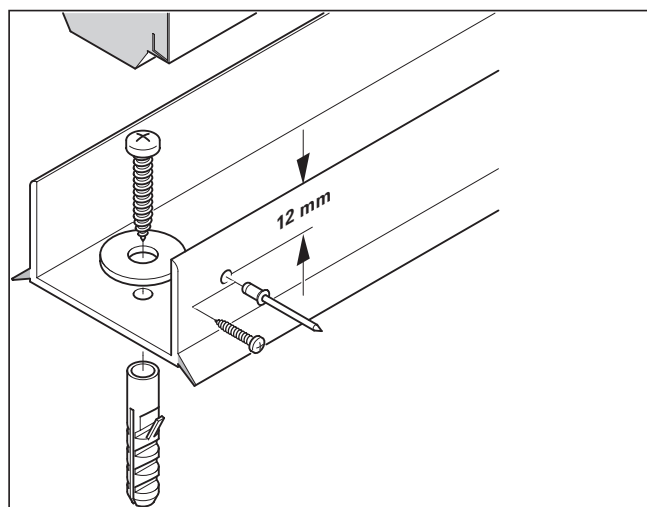

- ➔ Screw U-profiles to floor of the installation space at the intended position.
- ➔ Note the position of the door.
- ➔ Place wall elements into U-profiles.
- ➔ Rivet or screw wall elements with U-profiles.
- ➔ Make sure that the wall elements are perpendicular.

Door element without floor

ⓘ Door element without floor is delivered with securing for transportation and without door frame heating.

- ➔ Remove the door element's securing for transport before installation.

4.5 Assembling room elements

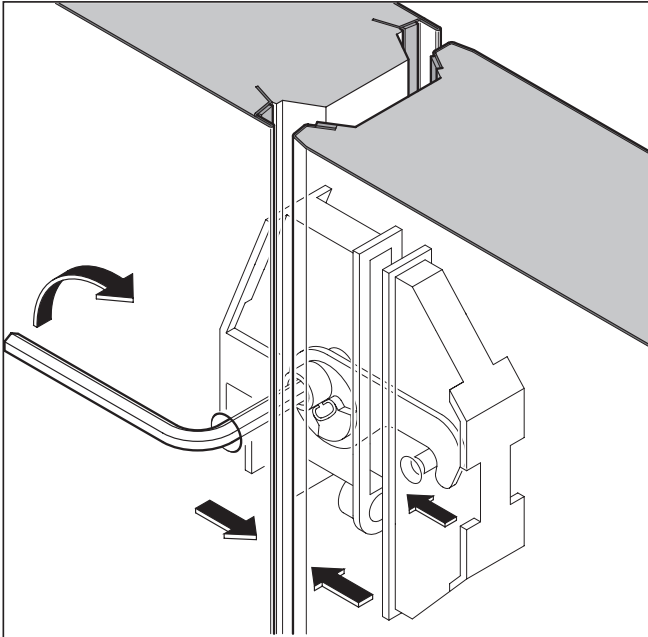

Connect room elements as follows:

- Activate eccentric cam locks from inside of room. First, only operate the centre locks to enable the alignment of the walls.
- Check whether the room elements' eccentric cam locks can be opened by turning left with Allen key.
- Make sure that the room elements are not more than 12 mm apart from one another.
- Push room elements together and close eccentric cam locks by turning right.

4.6 Assembling floor elements

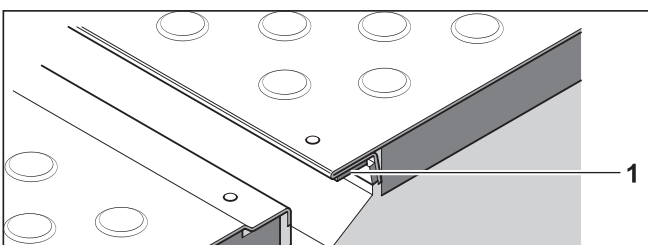

i Floor elements with stainless steel top plate are fit with joint tape on the overlapping on the spring side.

- Make sure that there is no protective film on the joint tape.
- Make sure that the joint tape (1) are not damaged during assembly.

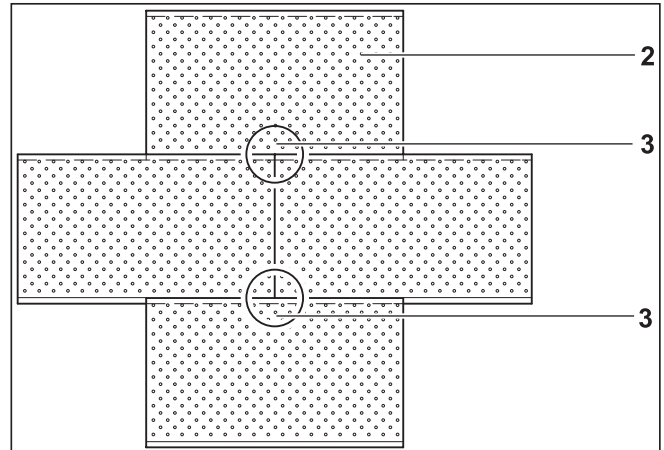

- In the case of floor elements (2) with 1 and 2-side connection, fill the connection point (3) with the enclosed sealant during assembly.
- Do not put any load on the floor elements to be assembled during tensioning.
- Make sure that the floor elements to be assembled can move freely.

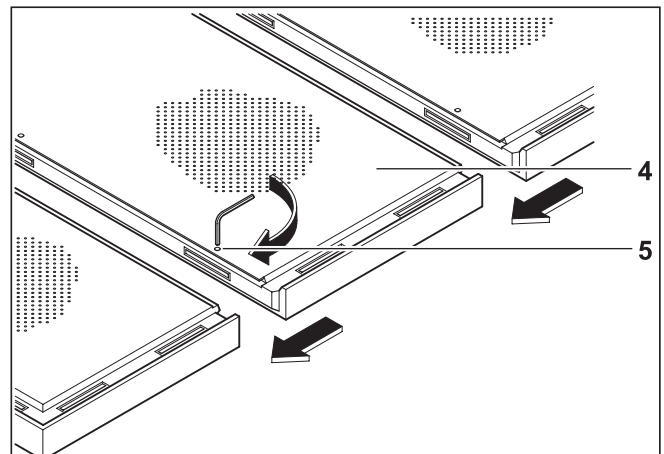

- Push floor elements (4) together.
- Tighten eccentric cam lock (5) on the exterior.
- If necessary, push the opposing side of the floor element with a pry bar.
- Make sure that the floor elements are not damaged.
- Tighten the eccentric cam lock on the opposing exterior side.
- Tighten interior eccentric cam locks.

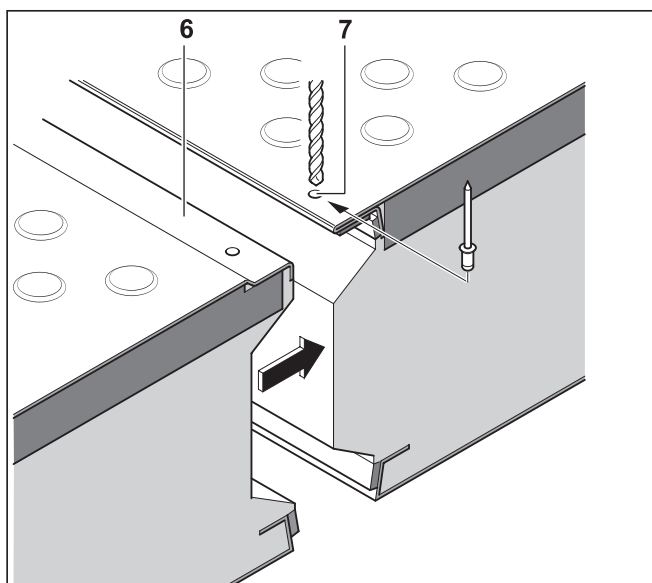

- ➔ Drill a hole into the plate end of the opposing element (6) through the hole provided (7) in the plate surface of the spring side.
- ➔ Rivet the overlapping of the floor elements.

Drill holes

- ➔ Use a suitable lubricant for drilling.
- ⓘ *Depending on the floor, make the drill holes according to the specifications below.*

1600 N floor:

- Drill with Ø 3.3 mm
- Drill hole at least 10 mm deep.
- Pop rivet with Ø 3.2 mm
- Hand riveter with mouthpiece (suitable for stainless steel) for 3.2 mm pop rivet

3000 N, 4000 N and 5000 N floor:

- Drill with Ø 5.0 mm
- Drill hole at least 24 mm deep.
- Countersunk rivet with Ø 5.0 mm
- Hand riveter with mouthpiece (suitable for stainless steel) for 5.0 countersunk rivet

4.7 Seal operating apertures in the cam locks in the floor elements

- ⓘ *Using a steel hammer will run the risk of contamination with outside rust.*

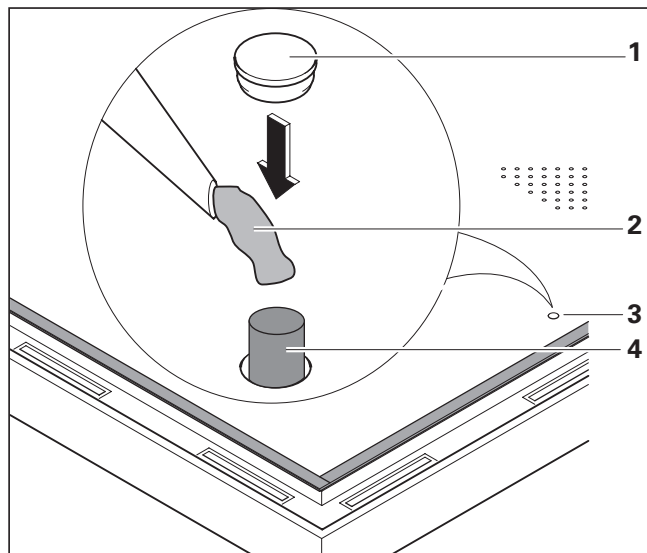

- ➔ Fill operating aperture (3) with the supplied heat insulation foam filler (4).
- ➔ Fill the operating aperture (3) by spraying it with the enclosed sealant (2).
- ➔ Seal operating apertures (3) with plugs (1).
- ⓘ *Use suitable plugs depending on the floor.*

1600 N floor:

- Plug Ø 15.0 mm stainless steel

3000 N, 4000 N and 5000 N floor:

- Plug Ø 15.1 mm stainless steel, knurled

4.8 Assembling wall elements

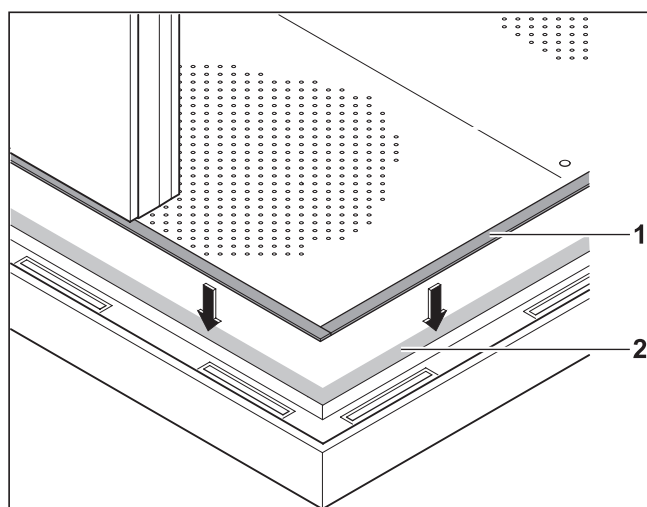

- ➔ Make sure that the inner floor panel is free of grease and dust in the area of the inner wall panel (2).

Assembly

- Adhere enclosed sealant (1) to cleaned edge of the inner floor panel.
- Remove protective film from joint tape.
- Begin wall assembly with corner element.
- Push elements together and tighten eccentric cam locks. First, only operate the centre locks to enable the alignment of the walls.
- Align wall element horizontally and vertically.
- In the case of longer room elements, there may be protrusions at the corners caused by natural tolerance. We recommend starting with the assembly of the room at the corner areas. Connect the elements with the floor and the ceiling according to the order defined in the drawing. Install the final walls from inside to outside with the aid of vacuum suction devices. Make sure that the last wall set is flush with the other room walls at the upper edge.

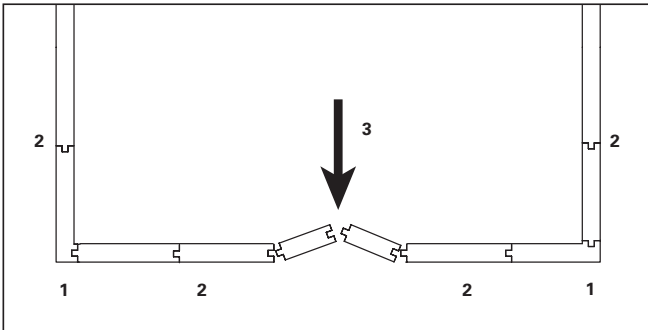

4.9 Assembling partition wall of combination rooms without tongue and groove system

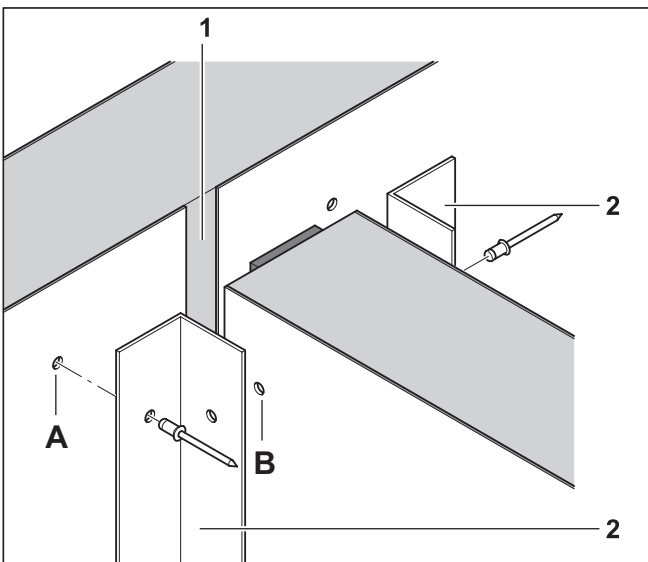

- Place partition wall at intended location.
- Fasten partition wall to the wall, ceiling and floor elements with the enclosed fastening profiles (2).
- Make sure that the cover plate (1) is interrupted between the elements to prevent condensation from forming.

4.10 Mounting the door

- ⓘ The single-leaf door is delivered pre-mounted in the door frame.

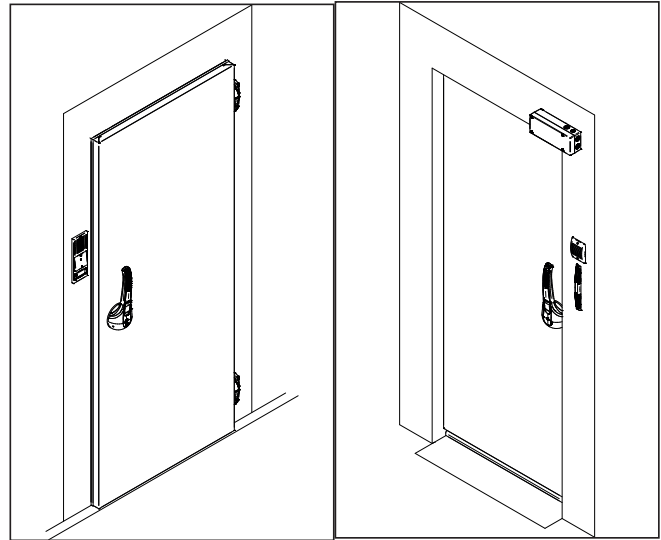

- Align door frame horizontally and vertically.

4.11 Mounting ceiling elements

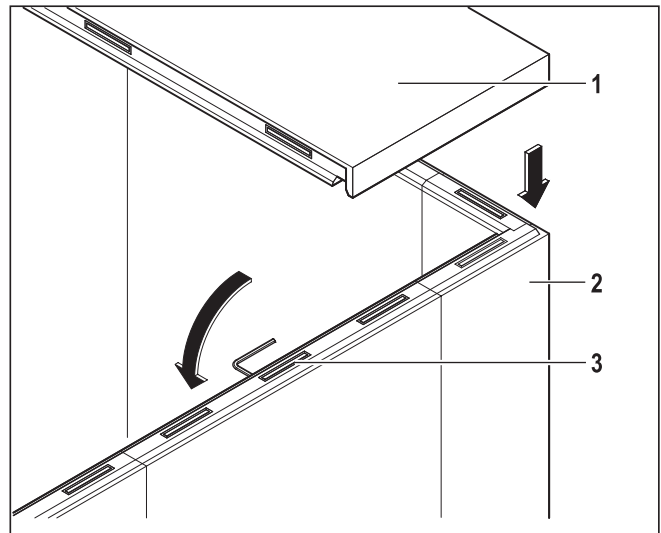

- Place ceiling element (1) onto wall elements (2) and tighten eccentric cam locks (3).

If any of the elements become displaced:

- Open the eccentric cam locks and align the elements.
- Retighten the eccentric cam locks in the following order: wall/wall, wall/ceiling and wall/floor.

4.12 Seal operating apertures in the cam locks in the wall and ceiling elements

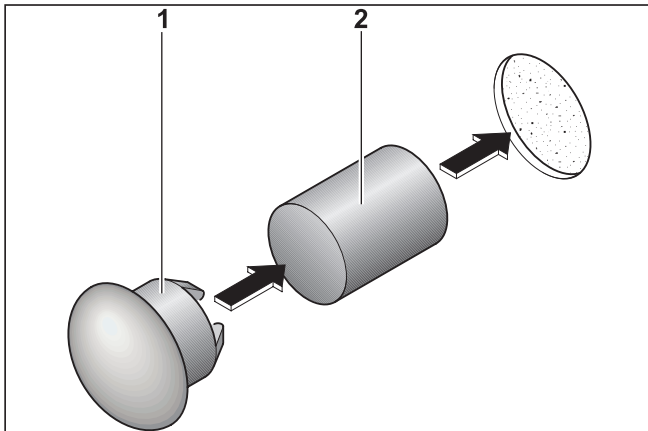

- Fill operating apertures 3 with the supplied heat insulation foam fillers (2).
- Seal operating apertures with plastic plugs (1).

4.13 Mount doorsill (for rooms with floor elements)



DANGER!

Risk of death due to electric shock!

- ▶ Only drill out the intended holes in the stainless steel doorsill.
- ▶ Do not drill any additional holes.

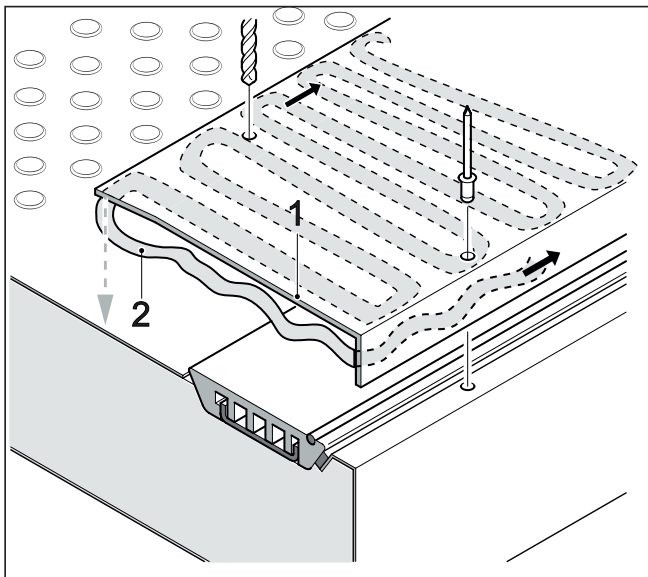

- Place the stainless steel doorsill (1) in the middle between the door soffit on the floor element and align.

- Use the stainless steel doorsill as a template for fixing holes (Ø 3.3 mm) and drill out.
- Remove drilling chips.
- In order to prevent moisture from getting in, apply sealing strip with the enclosed sealant (2) on the entire surface of the bottom of the doorsill.
- Distribute sealing strip.
- Lay stainless steel doorsill onto floor element and align it.
- Fasten stainless steel doorsill with enclosed rivets.
- Seal stainless steel doorsill with enclosed sealant:
 - between door soffit and doorsill
 - between floor and doorsill
- Remove any sealant that escapes.

4.14 Remove transport securing plates

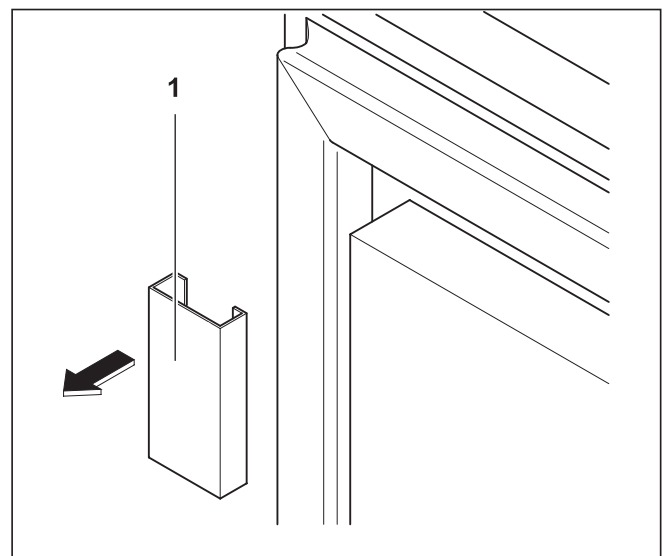

ⓘ The magnetic sealing frames on the doors are protected from mechanical damage by securing plates.

Before initial operation or door adjustment:

- Remove transport securing plates (1).

4.15 Adjusting the door

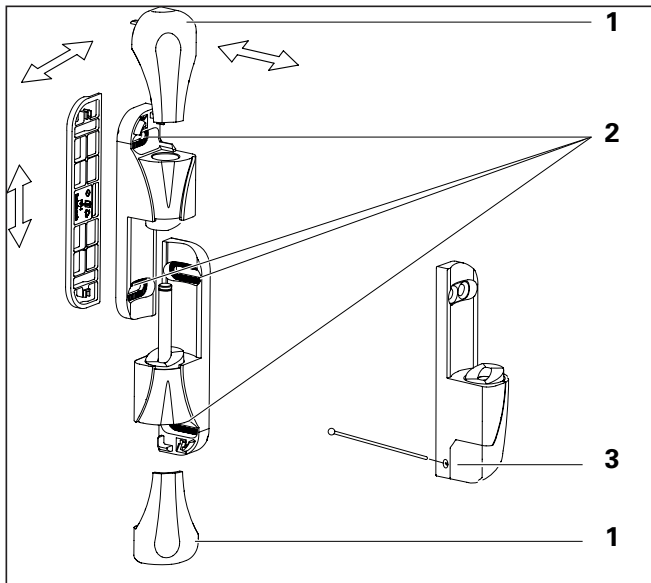

Adjust hinges when the door is closed in order to compensate for deviations if:

- the magnet sealing profile is not placed evenly all the way around
- the sealing lip of the floor seal is not lying on the sill or on-site floor.

Adjust hinges as follows:

- Remove cover caps (1) from door hinges.
- Open door.
- Insert thin pin, small Allen key or similar into opening (3) in the cap in order to loosen the cap seal.
- Loosen the screws (2).
 - Adjust the door leaf in depth and horizontal position using the screws (2).
 - Adjust the door leaf vertically with the hinge pin.

Adjust door vertically:

- Turn hinge pin with Allen key (8 mm) until the door has the desired height.
- Make sure that the hinge can move easily in all adjustment areas.
- Adjust all of the door's hinges.

ⓘ *Maximum adjustment range: +/- 3 mm.*

4.16 Light test

- Conduct a light test to check whether light gets into the dark room through an open seal point.

4.17 Attaching the cover caps

- Place the cover caps onto the hinge so they are centred.
- Fit the narrow side of the cover caps in the recess in the hinge housing into slide blocks.
- Lock the mounting lugs into place by pushing up or down on the cover caps.

4.18 Fastening the striker

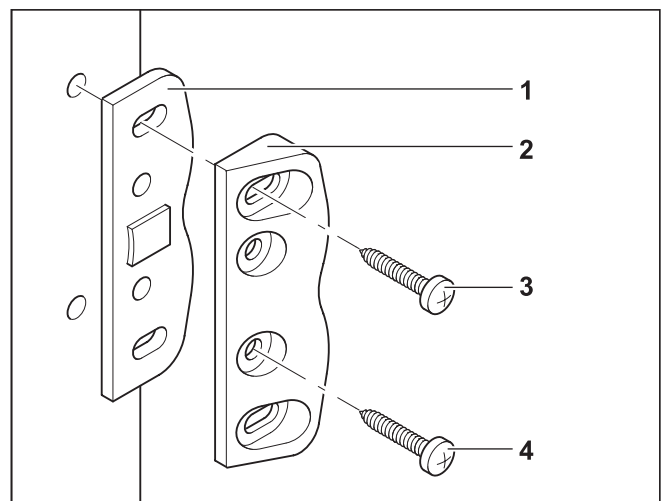

ⓘ *The striker of the rotary lever lock is adjusted at the factory.*

- After assembly or door adjustment, check whether lug of the rotary lever lock clicks into place behind the striker (2).

If necessary, readjust the striker as follows:

- loosen the striker screws (3).
- If necessary, place a spacer (1) between the door frame and striker.
- Fix the striker into the slots with screws (3) and tighten the screws.
- Check whether the door is tight.
- Pre-drill fastening for round holes (Ø 3.7 mm).
- Additionally fix the striker into the slots with the enclosed screws (4).

4.19 Mechanical work on the door or porthole

DANGER! **Risk of death due to electric shock from damaged wires!**

⚠ Do not conduct any mechanical work (such as drilling or sawing) on the inside or outside of the door or porthole in the safety zone (1).

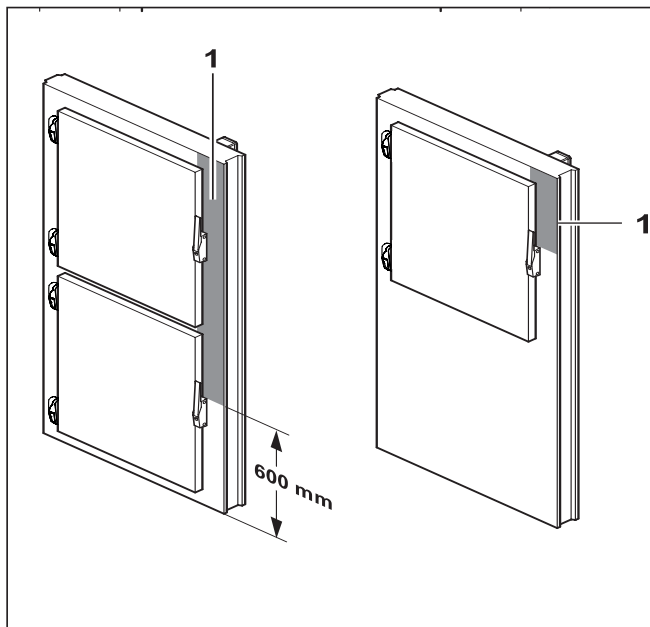
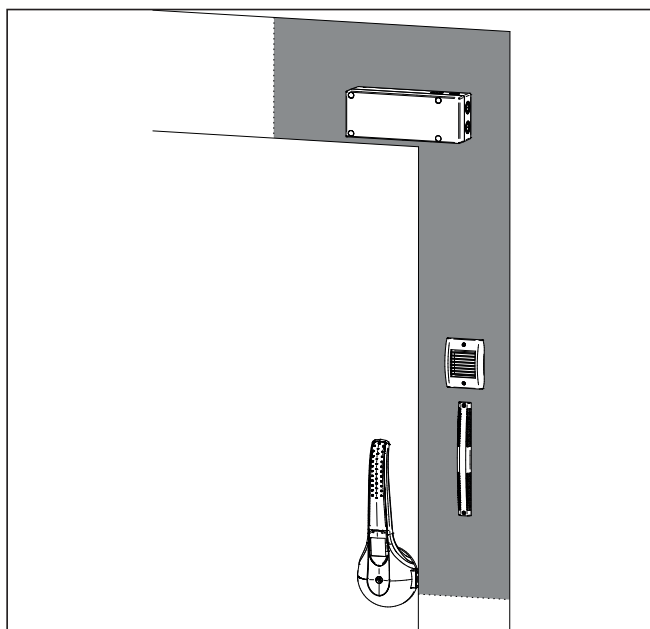

ⓘ *Electrical components are foamed in place in the grey-marked safety zone 1. Damage to the electrical components or wires poses the risk of electric shock.*

- ➔ Observe safety zone (1) before commencing mechanical work on the door or porthole.
- ➔ Makes sure that mechanical work will only be conducted outside of the safety zone.

4.20 Rearranging the luminaries

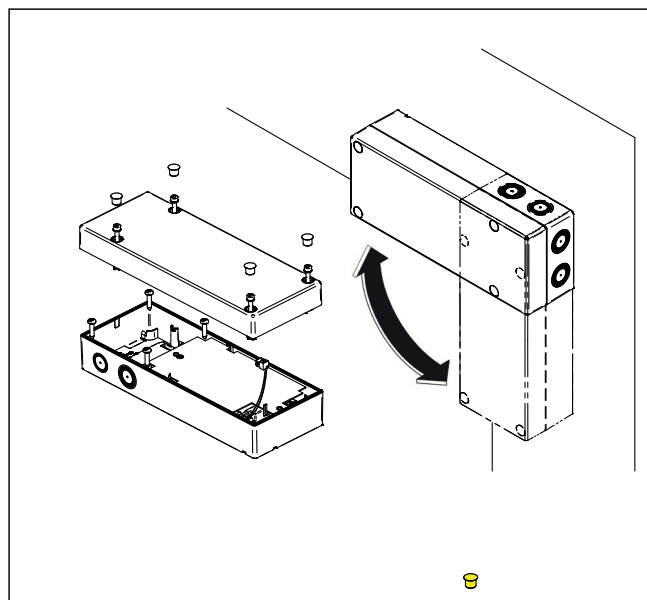

ⓘ *Moisture-proof luminaries and junction box are mounted at the factory on the inside of the door frame.*

ⓘ *The junction box with luminaries can be displaced by 90°.*

- ➔ Remove the upper part of the lamp by loosening the 4 screws.
- ➔ Loosen the fastening screws.
- ➔ Turn lamp by 90° and fix it in a new position with the fastening screws.
- ➔ Re-attach the upper part of the lamp and fasten it with the 4 screws.
- ➔ Attach the cover plugs.

5 Sealing of openings and cut edges

ⓘ *Any subsequent processing of the coated cell elements (e.g. drilling, sawing, etc.) requires the application of corrosion protection!*

- ➔ Subsequent treatment of cut edges: All cut edges of subsequently installed openings, cutouts, etc. must be treated with a suitable means of corrosion protection (e.g. zinc dust paint).
- ➔ Subsequent treatment of boreholes/openings:
 - Openings for refrigerant piping must be treated with corrosion protection (e.g. zinc dust paint or a comparable product).
 - After installation of the piping, it must always be sealed (e.g. with refrigerant filler).
 - The following applies to all subsequently installed boreholes/openings with a gap dimension of less than 5 mm:
 - The subsequently installed hole must be

filled with acetic acid-free sealant.

- In the case of subsequently installed openings, e.g. for cable bushings, through-bolting of fasteners, the gap must also be filled with acetic acid-free sealant.
 - Any superfluous sealant must be removed after sealing.
 - The following applies to all subsequently installed boreholes/openings with a gap dimension of larger than 5 mm:
 - The cut edges must be treated with a suitable corrosion protection (e.g. zinc dust paint). Afterwards, the gap between the inserted medium and the element must be filled with PU foam.
- ⇒ Failure to comply with this will invalidate the warranty for the product!

6 Electrical connections



DANGER!

Risk of death due to electric shock!

- ▶ Only have work for the mains connection and installation of protective measures (GFCI circuit breaker) conducted by a specialised electrical contractor.
- ▶ Observe the applicable regulations (EN, ISO, VDE, etc.) and connection conditions from the relevant energy supply company.



DANGER!

Risk of death due to electric shock!

- ▶ Before establishing the mains connection, shut off the mains power and secure it to prevent it from being turned back on.

- ⇒ Only have work for the mains connection and installation of protective measures (GFCI circuit breaker) conducted by a specialised electrical contractor.

- ⓘ *A device which simultaneously disconnects all non-grounded conductors with at least 3 mm contact opening width from the mains (plug connection or 2-pole switch) is to be installed in the supply line to the junction box (integrated in moisture-proof lamp).*
- ⓘ *Wire type of at least H05VV-F3G1.5 or NYM-J 3x1.5 should be used, unless additional requirements call for a higher-level type.*

- ⇒ Attach edge protection.
- ⇒ Remove the cover of the lamp.
- ⇒ Penetrate cable feed-through of the lamp and insert the enclosed feed-through sleeve.
- ⇒ Connect to on-site mains connection.
- ⇒ Make sure that the connection line in the room area is laid firmly.
- ⇒ Switch on mains voltage and check the function of the electrical system.
- ⇒ A 2A fuse is installed in the lamp. This must be checked before commissioning.

Only if the unit is not from Viessmann:

- ⇒ guide connection line through room ceiling.
- ⇒ Lead the connecting cable through the feed-through sleeve and connect it in the junction box L1, N and PE integrated in the light fitting according to the circuit diagram (depending on the protection class).

Small thermostat in junction box (only for version without lamp) for doors with heating:

- activates via digital thermometer at +4°C
- deactivates the frame and valve heater at approx. 4 °C when the temperature rises.
- ⇒ Observe the small thermostat's hysteresis range and tolerance.
- ⓘ *The small thermostat will not activate the heater if the junction box is on the warm side.*
- ⇒ Connect heater without small thermostats.
- ⇒ Disconnect the heater when disconnecting the system or when operating the room in the positive range.

7 Commissioning

7.1 Commissioning the cold room

- ➔ Clean and air out the cold room after assembly (siehe Kap. „7 Reinigung“ auf Seite 15).

The room is ready for operation.

- ➔ Observe the corresponding operating instructions for commissioning the refrigeration unit.
- ➔ Dial the cold room down to the desired temperature.
- ➔ Make sure that the refrigerated goods are only placed in the cold room once the desired temperature has been reached.
- ➔ Then double-check the temperature in the cold room and correct the refrigeration unit regulator as necessary.
- ➔ Have the pressure equalisation valve checked by a specialised refrigeration contractor.
- ⓘ *Permissible pressure differential in cold room max. 100 Pa (1 mbar).*
- ➔ Check the function of the pressure equalisation valve regularly.
- ➔ Make sure that the outlet of the valve is not covered on the inside or outside (by refrigerated goods, for instance).

8 Cleaning



DANGER!

Risk of death due to electric shock!

► Before any cleaning work, pull the power plug or shut off the mains power and secure it to prevent it from being turned back on.

- ⓘ *Tecto cold rooms and deep-freezing rooms are not watertight.*
- ⓘ *Observe industry-specific hygiene requirements.*
- ⓘ *Create hygiene plan depending on use and products stored.*
- ➔ Regularly check Tecto cold rooms and deep-freezing rooms for soiling after the initial start-up and clean as required.

Cleaning interval depends on:

- degree of soiling
- Surrounding conditions
- ➔ Do not use pointed or sharp-edged objects.

Elements with a powder-coated sheet steel or stainless steel surface:

- ➔ Do not spray-clean the inside or outside of the walls, ceilings, elements with electrical components (such as door frame) and unit with water.
- ➔ Wipe out the inside of the room, dry it completely and air it out well.
- ➔ Do not use any scouring agents or cleaning agents that contain solvents.
- ➔ Wipe the outside of the room with a damp cloth and dry it off.

Standard floor:

- ➔ Wipe with damp cloth only.
- ➔ Do not clean standard floors with water jet.
- ➔ Make sure there is no water on standard floors.

Tub floor:

- ➔ Wipe with damp cloth only.
- ➔ Only expose tub floor to standing water or water jet for a short amount of time.

For all floors:

- ➔ Regularly wash off door seals with neutral soap solution and dry them off.
- ➔ Do not use acetone or cleaning agents that contain solvents to clean the seals.
- ➔ Treat stainless steel room floor with standard commercial stainless steel cleaning agents.
- ➔ Seal stainless steel surface with stainless steel care product.
- ➔ Observe product information on cleaning agents.

9 Decommissioning

For prolonged downtime:

- ➔ Pull the power plug or shut off the mains power.
- ➔ Ensure adequate ventilation.

10 Technical data

10.1 Permissible loading on floor elements

Load Weight Class	Wheel	Wheel Load (N ^{**})		Wheel Load (N/m ²)
		1 - 4 cm ²	> 4 cm ²	
1.	Rubber	400	1.600	30.000
2.	PU-/Rubber	750	3.000	40.000
3.	PU-/Rubber	1.000	4.000	50.000
4.*	PU-/Rubber	1.250	5.000	50.000

* Load Weight Class 4) Special version for 5.000N floor: Extension of approval up to 6.000N possible after internal check.möglich nach interner Prüfung

** 10N ≈ 1Kg

11 Maintenance

 DANGER!	<p>Risk of death due to electric shock!</p> <ul style="list-style-type: none"> ▶ Ensure that maintenance work is carried out exclusively by trained qualified personnel. ▶ Disconnect power plug and secure to prevent reconnection before carrying out maintenance work.
--	--

- Conduct maintenance on TectoCell cold rooms and deep-freezing rooms at least once per year.
- You can reach our technical customer service at: +49 9281 814 908

12 Disposal

- Dispose of defective TectoCell cold rooms and deep-freezing rooms in an environmentally friendly manner according to applicable disposal regulations.

13 Standards and laws

- Comply with the applicable standards and laws:
 - EMC directive 2014/30/EG
 - Machinery Directive 2006/42/EC, DIN EN 378 (2008/2012)

14 Warranty

Excerpt from our warranty terms

The warranty period is 5 years. The warranty claim starts on the day of the delivery, which is to verified by delivery note or invoice. Malfunctions that can be attributed to poor workmanship or material defects, will be rectified free of charge within the warranty period.

Further claims, in particular for consequential damages, are excluded.

We shall assume no warranty for damages resulting from improper or inappropriate use, faulty installation or commissioning by the purchaser or third party, natural wear and tear, faulty or negligent handling, chemical or electrochemical and electrical impacts, provided that they cannot be attributed to our fault, failure to observe the installation, operating, and maintenance instructions, improper modifications or repair work by the purchaser or third party, and effects of parts of external origin.

15 Wiring diagram for revolving door SKI

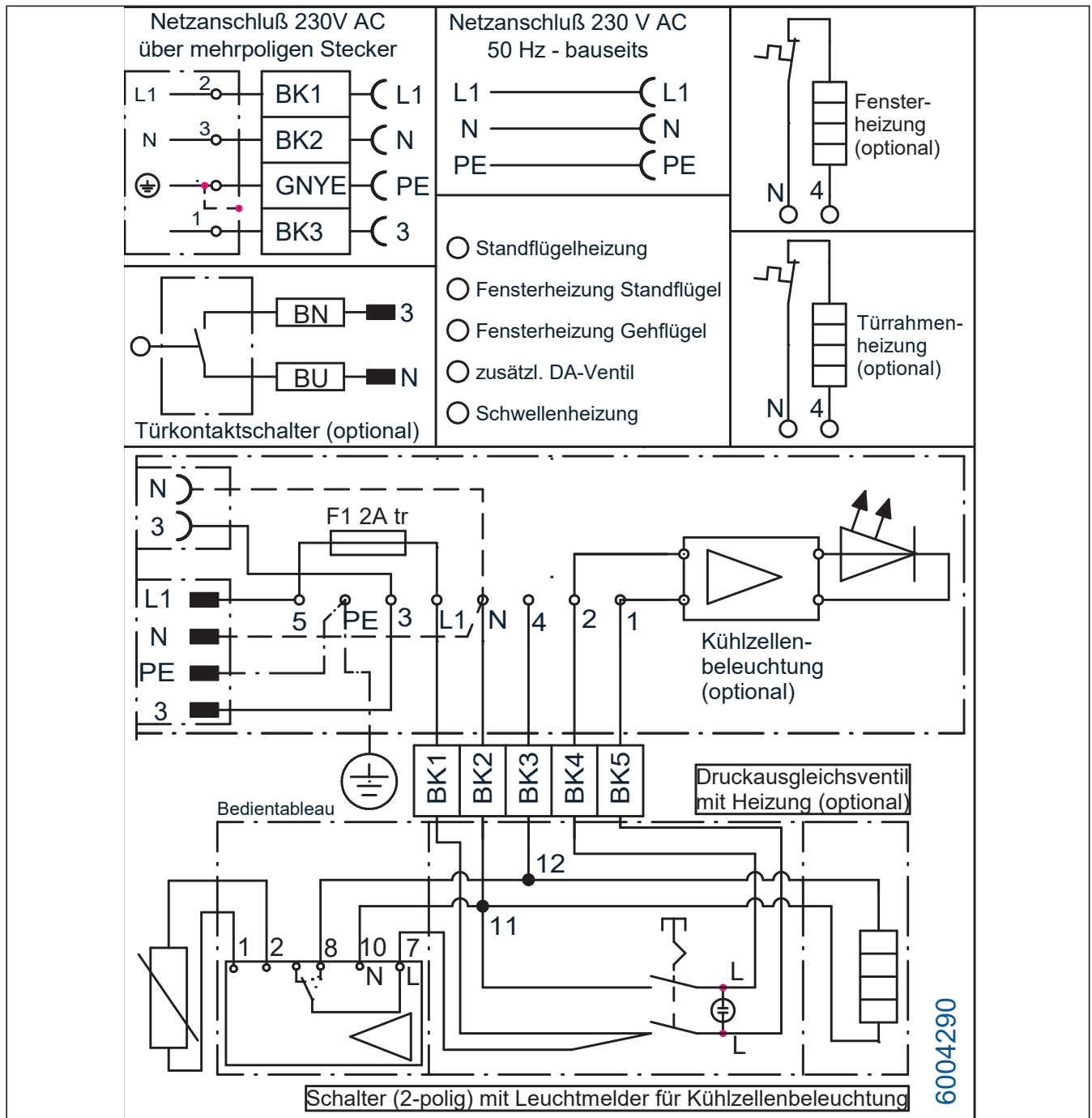

16 Wiring diagram for revolving door SKI

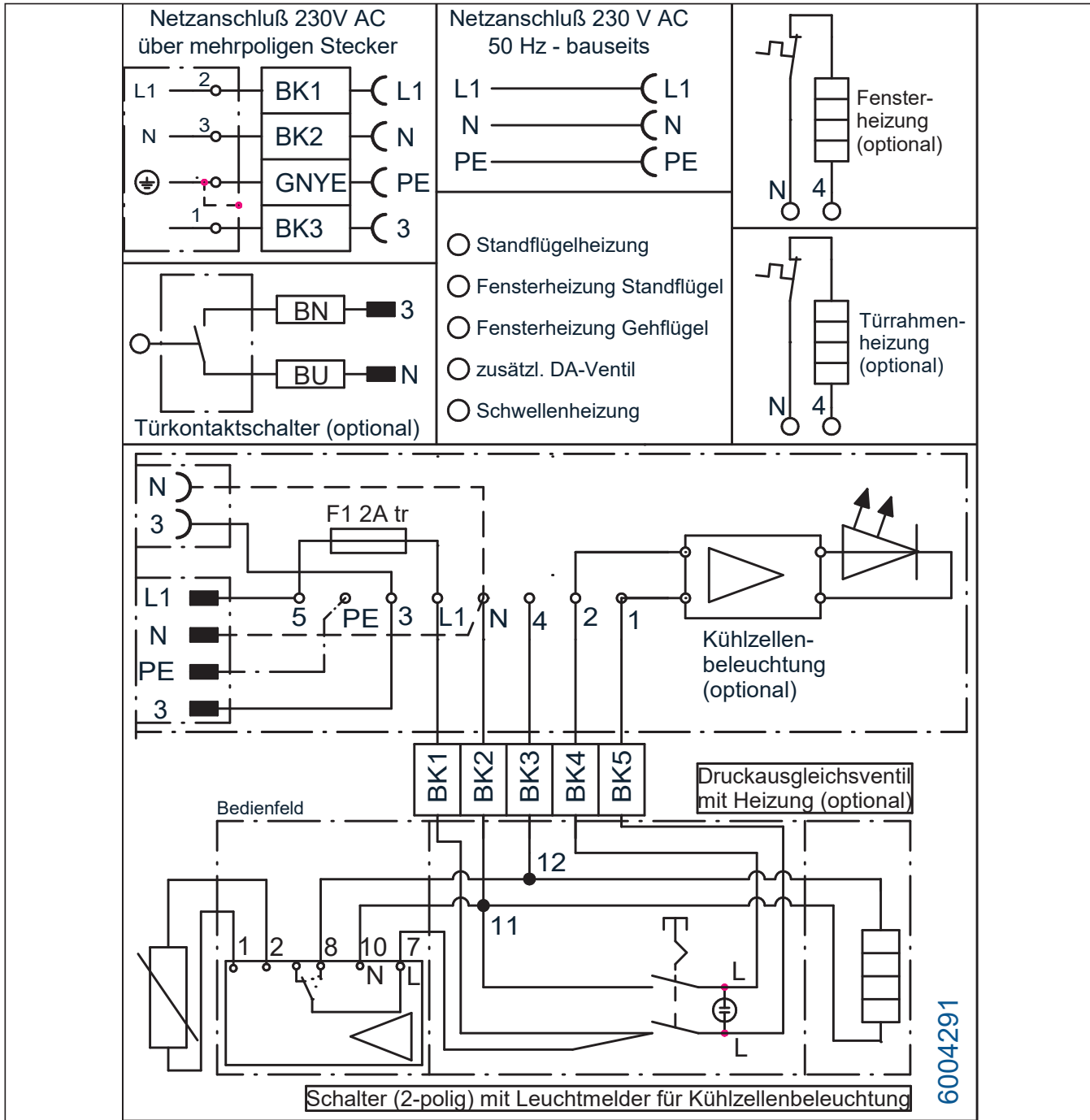

17 Wiring diagram for porthole

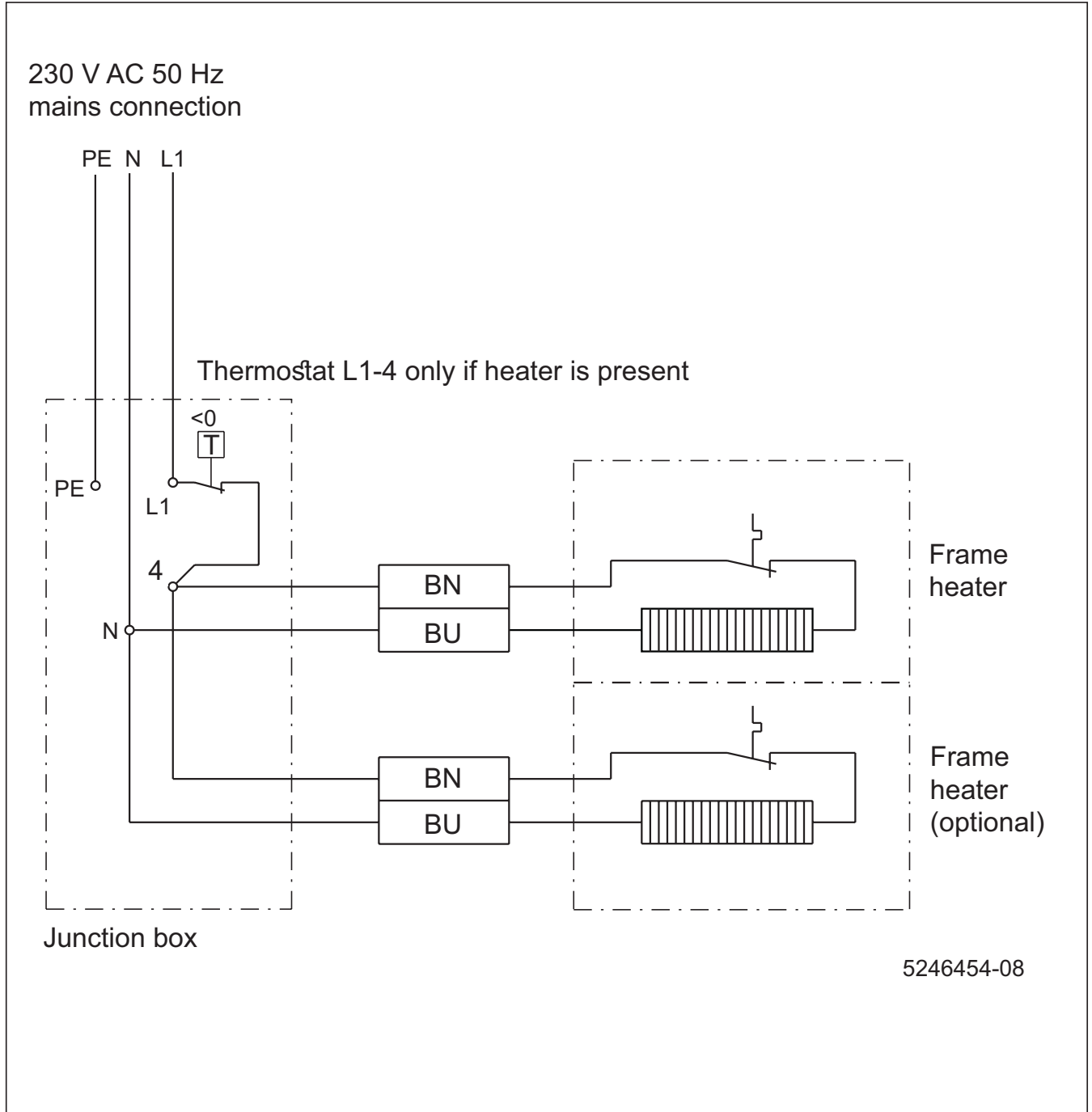

Unit controller



Contents

1	User Guide	4		
1.1	Structure of the Installation and Operating Instructions....	4		
1.1.1	Warnings	4		
1.1.2	Additional symbols	4		
1.2	Requirements for personnel	4		
1.3	Target groups.....	4		
1.3.1	Maintenance personnel.....	4		
1.3.2	Qualified electricians.....	5		
1.3.3	Refrigeration technology	5		
1.3.4	Heating installer	6		
1.3.5	Assembly personnel.....	6		
1.3.6	Authorised qualified personnel	7		
1.4	Related documents	8		
1.5	Safekeeping	8		
2	Safety and Dangers	8		
3	Intended Use	8		
4	Foreseeable misuse	8		
5	Operation	8		
5.1	Control unit.....	8		
5.2	Display symbols	9		
5.3	Normal mode.....	9		
5.3.1	Standard display	9		
5.3.2	Control field lock	9		
5.3.3	Stand-by function.....	10		
5.4	User menu	10		
5.4.1	Setting required temperature.....	10		
5.4.2	Setting time (RTC)	10		
5.4.3	Display current temperature	11		
5.4.4	Display alarm list.....	11		
5.5	Installer menu.....	11		
5.5.1	Set types of defrosting	12		
5.5.2	Manual defrosting	12		
5.5.3	Periodic defrosting	12		
5.5.4	Defrosting according to time lines	12		
5.5.5	Adjusting humidity	13		
5.5.6	Activating time (RTC) for defrosting.....	13		
5.5.7	Activating door contact switch	13		
5.5.8	Protecting the control against.....	13		
5.5.9	Reset to factory settings.....	14		
6	Alarm messages	14		
7	Diagrams	16		
7.1	Switch hysteresis principle – evaporator fan.....	16		
7.2	Hysteresis temperature alarm.....	16		
8	List of Parameters	16		
8.1	Setting target temperature.....	16		
8.2	Compressor run time	16		
8.3	Defrosting.....	17		
8.4	Evaporator fan.....	18		
8.5	Alarms and times.....	18		
8.6	Condenser fan.....	19		
8.7	Door contact switch	19		
8.8	Real-time clock (RTC)	19		
8.9	Manual defrosting	19		
8.10	Other parameters.....	19		

1 User Guide

All important information for assembly, installation and commissioning is summarised in the assembly and operating instructions.

If you have any questions, please contact your Viessmann specialist partner. The current address is on the back page.

1.1 Structure of the Installation and Operating Instructions

1.1.1 Warnings

Structure of the warnings

Warnings are structured as follows:

 SIGNAL WORD!	Source of danger! Consequences of non-compliance. ▶ Measure to avoid the danger.
---	---

Graduation of the warnings

Warnings differ according to the type of danger as follows:

 DANGER!	Warns against an imminent threat of danger, which leads to death or serious injuries if it is not avoided.
---	--

 WARNING!	Warns against a possibly dangerous situation, which leads to death or serious injuries if it is not avoided.
---	--

 CAUTION!	Warns against a possibly dangerous situation, which leads to moderate or minor injuries if it is not avoided.
---	---

NOTE	Warns against a possibly dangerous situation, which leads to damage to property or the environment if it is not avoided.
-------------	--

Tips, notes, and recommendations

- ① Gives the user tips, notes, or recommendations on using the product efficiently.

1.1.2 Additional symbols

Handling instructions

Handling instructions ask you to carry out an operation or a work step. Handling instructions should always be carried out individually and in the specified sequence.

Structure of the handling instructions:

- ➞ Instructions for an operation.

Results if required.

Lists

Structure of the unnumbered lists:

- List level 1
 - List level 2

Structure of the numbered lists:

1. List level 1
 - 1.1. List level 2

1.2 Requirements for personnel

- ➞ Ensure that only authorised and trained persons operate, maintain or repair the machine.
- ➞ Make sure that all persons who operate, maintain or repair the machine are of the specified minimum age.
- ➞ Ensure that the training of personnel includes theoretical information (technology and safety) and practical training on the machine.
- ➞ Make sure that the personnel have read and understood the operating instructions and the supplied documentation.
- ➞ Ensure that personnel to be trained, taught in, instructed or trained in general training work on the machine only under the constant supervision of an experienced person.
- ➞ Regularly check that personnel are working in a safety-conscious and hazard-conscious manner.
- ➞ Clearly define the responsibilities of the personnel for operation, setup, maintenance and repair.

1.3 Target groups

These instructions are aimed exclusively at authorized specialists.

- ➞ Have electrical work carried out only by qualified electricians. For further information, see VDE 0105–100 and IEC 60050–826.
- ➞ Assembly and initial start-up may only be carried out by the manufacturer or qualified personnel appointed and authorised by the manufacturer.
- ➞ Work on the refrigeration system may only be carried out by trained refrigeration staff.

1.3.1 Maintenance personnel

Responsibility

The maintenance personnel have the following tasks:

- ➞ Read the installation and operating instructions
- ➞ Read the supplied documentation.
 - Operating instructions for components
 - Operating instructions from third-party manufacturers

- Supplementary instructions
- Maintain the machine for safe and reliable operation.
- Carry out all prescribed maintenance work.
- Wear protective clothing.
- Observe the safety regulations at the place of use.
- Report all safety-impairing modifications to the machine to the operator.
- Conversions on the machine may only be carried out after consultation with the manufacturer.
- If possible, use original spare parts.

Requirement

Maintenance personnel have the following qualifications and skills:

- Has reached the statutory minimum age.
- Is physically and mentally suitable for servicing the machine.
 - Sufficient vision
 - Adequate hearing ability
 - Fast response time
- Has the authorisation required to maintain the machine.
- Is able to estimate distance, height and distances.
- Has knowledge of the machine and the hazards.
- Knows all procedures and precautions for maintenance.
- Has knowledge of how to handle special tools for maintenance and repair.
- Is not under any physical or mental impairment that reduces any of the prescribed requirements.
- Not under the influence of alcohol.
- Not under the influence of drugs.

1.3.2 Qualified electricians

Responsibility

Tasks of the electrical technician:

- Read the instruction manual.
- Read the supplied documentation.
 - Operating instructions for components
 - Operating instructions from third-party manufacturers (attachments, etc.)
 - Special sheets
- Maintain and repair the machine for safe and reliable operation.
- Carry out all prescribed maintenance and repair activities.

- Disconnect the main isolator switch of the power supply system and secure it against being switched on again.
- Unambiguously define and label the workplace.
- Wear protective clothing.
- Employ adapted tools.
- Observe the safety regulations at the place of use.
- Report all safety-impairing modifications to the machine to the operator.
- Conversions on the machine may only be carried out after consultation with the manufacturer.
- If possible, use original spare parts.

Requirement

Qualifications and skills of qualified electricians:

- Has reached the statutory minimum age.
- Is physically and mentally suitable for servicing the machine.
 - Sufficient vision
 - Adequate hearing ability
 - Fast response time
- Has the authorisation required to maintain the machine.
- Has the ability to:
 - estimate distance, height and distances.
 - assess work correctly.
 - identify hazards.
 - to initiate safety measures.
- Has knowledge of the machine and the hazards.
- Knows all procedures and precautions for maintenance.
- Has knowledge of how to handle special equipment for maintenance and repair.
- Is not under any physical or mental impairment that reduces any of the prescribed requirements.
- Not under the influence of alcohol.
- Not under the influence of drugs.

1.3.3 Refrigeration technology

Responsibility

Tasks of the refrigeration technician:

- Read the instruction manual.
- Read the supplied documentation.
 - Operating instructions for components
 - Operating instructions from third-party manufacturers (attachments, etc.)
 - Special sheets
- Maintain and repair the machine for safe and reliable operation.

- Carry out all prescribed maintenance and repair activities.
- Disconnect the main isolator switch of the power supply system and secure it against being switched on again.
- Unambiguously define and label the workplace.
- Wear protective clothing.
- Employ adapted tools.
- Observe the safety regulations at the place of use.
- Report all safety-impairing modifications to the machine to the operator.
- Conversions on the machine may only be carried out after consultation with the manufacturer.
- If possible, use original spare parts.

Requirement

Qualifications and skills of the refrigeration technician:

- Has reached the statutory minimum age.
- Is physically and mentally suitable for servicing the machine.
 - Sufficient vision
 - Adequate hearing ability
 - Fast response time
- Has the necessary authorisation to maintain and repair the machine.
- Has the ability to:
 - estimate distance, height and distances.
 - assess work correctly.
 - identify hazards.
 - to initiate safety measures.
- Has knowledge of the machine and the hazards.
- Knows all procedures and precautions for maintenance.
- Has knowledge of how to handle special equipment for maintenance and repair.
- Is not under any physical or mental impairment that reduces any of the prescribed requirements.
- Not under the influence of alcohol.
- Not under the influence of drugs.

1.3.4 Heating installer

Responsibility

Duties of the installer:

- Read the instruction manual.
- Read the supplied documentation.
 - Operating instructions for components
 - Operating instructions from third-party manufacturers (attachments, etc.)
 - Special sheets

- Maintain and repair the machine for safe and reliable operation.
- Carry out all prescribed maintenance and repair activities.
- Disconnect the main isolator switch of the power supply system and secure it against being switched on again.
- Unambiguously define and label the workplace.
- Wear protective clothing.
- Employ adapted tools.
- Observe the safety regulations at the place of use.
- Report all safety-impairing modifications to the machine to the operator.
- Conversions on the machine may only be carried out after consultation with the manufacturer.
- If possible, use original spare parts.

Requirement

Qualifications and skills of the installer:

- Has reached the statutory minimum age.
- Is physically and mentally suitable for servicing the machine.
 - Sufficient vision
 - Adequate hearing ability
 - Fast response time
- Has the necessary authorisation to maintain and repair the machine.
- Has the ability to:
 - estimate distance, height and distances.
 - assess work correctly.
 - identify hazards.
 - to initiate safety measures.
- Has knowledge of the machine and the hazards.
- Knows all procedures and precautions for maintenance.
- Has knowledge of how to handle special equipment for maintenance and repair.
- Is not under any physical or mental impairment that reduces any of the prescribed requirements.
- Not under the influence of alcohol.
- Not under the influence of drugs.

1.3.5 Assembly personnel

Responsibility

The installation personnel are responsible for the following:

- Read the instruction manual.
- Read the supplied documentation.
 - Operating instructions for components

- Operating instructions from third-party manufacturers
- Supplementary instructions
- ⇒ Set up the machine for safe and reliable operation.
- ⇒ Use personal protective equipment.
- ⇒ Observe the safety regulations at the place of use.
- ⇒ Report all safety-impairing modifications to the machine to the operator.
- ⇒ Conversions on the machine may only be carried out after consultation with the manufacturer.
- ⇒ If possible, use original spare parts.

Requirement

The installation personnel have the following qualifications and skills:

- Has reached the statutory minimum age.
- Is physically and mentally suitable for setting up the machine.
 - Sufficient vision
 - Adequate hearing ability
 - Fast response time
 - Is able to estimate distance, height and distances.
- Has the authorisation required to set up the machine.
- Knows the machine and the hazards.
- Is familiar with all procedures and precautions for set-up.
- Has knowledge of working with special tools for the body.
- Is not under any physical or mental impairment that reduces any of the prescribed requirements.
- Not under the influence of alcohol.
- Not under the influence of drugs.

1.3.6 Authorised qualified personnel

Responsibility

Authorised qualified personnel are responsible for the following:

- ⇒ Read the instruction manual.
- ⇒ Read the supplied documentation.
 - Operating instructions for components
 - Operating instructions from third-party manufacturers
 - Supplementary instructions
- ⇒ Maintain, repair, adjust and rebuild the machine for safe and reliable operation.
- ⇒ Carry out all maintenance and repair activities prescribed in the maintenance plan for the authorised qualified personnel.

- ⇒ Set all necessary parameters.
- ⇒ Carry out all planned conversions.
- ⇒ Unambiguously define and label the workplace.
- ⇒ Use personal protective equipment.
- ⇒ Use suitable tools for the work assignment.
- ⇒ Observe the safety regulations at the place of use.
- ⇒ Report all safety-impairing modifications to the machine to the operator.
- ⇒ If possible, use original spare parts.

Requirement

Authorised qualified personnel have the following qualifications and skills:

- Has reached the statutory minimum age.
- Is physically and mentally capable of maintaining, repairing, adjusting and converting the machine.
 - Sufficient vision
 - Adequate hearing ability
 - Fast response time

Is able to estimate distance, height and distances.

- Authorised qualified personnel are trained in accordance with country-specific laws, standards and guidelines.
- Authorised qualified personnel have the following skills:
 - Is able to assess work correctly.
 - Is capable of recognizing hazards.
 - Is able to take safety measures.
- Has knowledge and experience in the respective field of activity.
- Is familiar with relevant national standards.
- Has the authorization to service, repair, adjust and rebuild the machine.
- Knows the machine and the hazards.
- Has the option of proving the documented qualification.
- Is familiar with all procedures and precautions for maintenance, repair, adjustment and conversion.
- Has knowledge of how to use special tools for maintenance, repair, adjustment and conversion.
- Is not under any physical or mental impairment that reduces any of the prescribed requirements.
- Not under the influence of alcohol.
- Not under the influence of drugs.

1.4 Related documents

For safe and correct use of the device:

- ➔ Follow the additionally provided Installation and Operating Instructions.
- ➔ Follow the applicable standards and laws

1.5 Safekeeping

Keep the Operating Manual, including the related documents, handy in the vicinity of the device.

2 Safety and Dangers

NOTE!	Damage, reduced performance, or cooler breakdown due to improper modification of the control parameters! ▶ Ensure that only trained qualified personnel modify the control parameters.
-------	--

NOTE!	Property damage due to a lack of instruction! ▶ Ensure that only trained qualified personnel operate the control.
-------	---

NOTE!	Property damage due to a defective device! ▶ Ensure that only trained qualified personnel operate the control. ▶ Use control exclusively in original condition without unauthorized modifications and in technically perfect condition.
-------	--

3 Intended Use

Use regulation exclusively in connection with the units intended for it.

4 Foreseeable misuse

Use regulation exclusively as intended.

Use regulation exclusively for the approved use limits of the unit (see the Installation and Operating Instructions for the unit).

5 Operation

5.1 Control unit

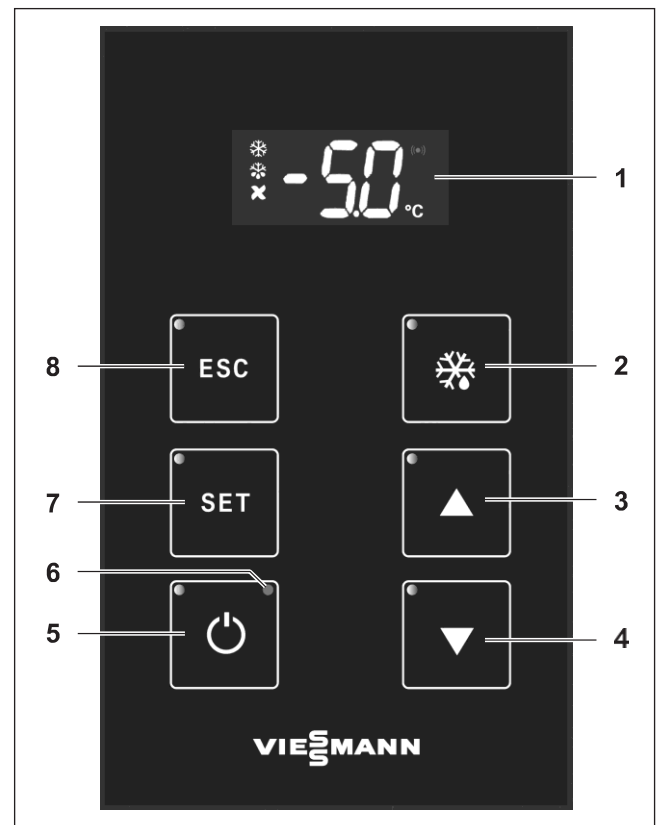

Figure 1: Control element

- 1 Display
- 2 Manual defrosting control field
- 3 Up control field
- 4 Down control field
- 5 Stand-by control field
- 6 LED lights up red in Stand-by
- 7 SET control field
- 8 ESC control button

The confirmation LEDs (upper left in the control field) light up if the buttons are operated.

- ① *By default, the value shown on the display corresponds to the cold room temperature (parameter ddd = 1). For the possible values of ddd parameter see "8.10 Other parameters" on page 16.*

NOTE!	Property damage due to improper operation! ▶ Operate control fields exclusively with the fingers.
-------	---

Deactivate control field lock

- ➔ Press any control field for at least 2 seconds.

Signal sounds and confirmation LED of the button lights up

Manual defrosting 2 control field:

- ➔ Press **Manual defrosting 2** control field for at least 5 seconds to:
 - Start or stop manual defrosting.

During defrosting, the display shows the last measured cold room temperature immediately before the defrosting.

- ⓘ *If the evaporator temperature is higher than the temperature set in parameter dS1, the display will flash 3x. No defrosting will take place.*

Up 3 control field:

- ➔ Press **Up 3** control field briefly to:
 - Scroll up the parameters.
 - Increase input values.

Down 4 control field:

- ➔ Press **Down 4** control field briefly to:
 - Scroll down the parameters.
 - Decrease input values.

Stand-by 5 control field:

- ➔ Press **Stand-by 5** control field for at least 5 seconds to activate or deactivate the stand-by function.





SET 7 control field:

- ➔ Press **SET 7** control field briefly to:
 - Open the user menu.
 - Confirm entries and modified parameter values.
- ➔ Press **SET 7** control field for at least 5 seconds to:
 - Open the password entry to the installer level.

ESC 8 control field:

- ➔ Press **ESC 8** control field briefly to:
 - Move up one level.
 - Cancel entry of parameter values.

5.2 Display symbols

Meaning Symbol	Symbol lights up	Symbol flashes	Symbol does not light up
Defrosting 	Defrosting in progress Defrosting started automatically	Defrosting in progress Defrosting started manually	Defrosting not running
Alarm 	Alarm on		Alarm off
Evaporator fan 	Evaporator fan running		Evaporator fan not running
Compressor 	Compressor running	Cooling request pending Compressor not running (e.g. minimum downtime of compressor not yet elapsed, door open)	Compressor not running No cooling request

5.3 Normal mode

5.3.1 Standard display

Display shows current cold room temperature.

5.3.2 Control field lock

- ⓘ *When the control field lock is active, the functions of the control fields are inactive.*

Control field active:

- After switching on Unit (see unit's Installation and Operating Instructions)
 - If no entry is made within 90 seconds.
- ➔ To deactivate control field lock: press any control field for at least 2 seconds.

Signal sounds and confirmation LED of the control field lights up.

- ➔ Press desired control field.

5.3.3 Stand-by function

① *In the active stand-by mode, nothing appears in the display and LED 6 lights up red.*

To activate stand-by function:

- ➔ Deactivate control field lock: press any control field for at least 2 seconds.

Signal sounds and confirmation LED of the control field lights up.

- ➔ Press **Stand-by 5** control field for at least 5 seconds.

Control switches to stand-by. **LED 6** lights up red.

To deactivate stand-by function:

- ➔ Press **Stand-by 5** control field for at least 5 seconds.

Display shows current cold room temperature.

5.4 User menu

To access the user menu:

- ➔ Deactivate control field lock: press any control field for at least 2 seconds.

Signal sounds and confirmation LED of the control field lights up.

- ➔ Press **SET 7** control field briefly.

Display shows *SEt*.

To scroll in the user menu:

- ➔ Scroll through the parameters using **Up 3** or **Down 4** control fields.

Parameters of the user menu:

Parameters:	Abbreviated designation
SEt	Setting required temperature in the cold room
AL	Display alarm list
Pb1	Display of actual cold room temperature
Pb2	Display of actual evaporator temperature
Pb3	Display of actual condenser temperature
IdF	Firmware mask
rEL	Software status
LAn	No function assigned

① *If no control field is pressed for approx. 90 seconds, the parameter entry is automatically terminated. Unconfirmed values are not adopted.*

5.4.1 Setting required temperature

To set the required value:

- ➔ Deactivate control field lock: press any control field for at least 2 seconds.

Signal sounds and confirmation LED of the control field lights up.

- ➔ Press **SET 7** control field briefly.

Display shows *SEt*.

- ➔ Select parameter SEt in the user menu.

- ➔ Press the SET 7 control field.

- ➔ Set the desired target temperature using the **Up 3** or **Down 4** control fields.

- Normal refrigeration: -5 °C to +15 °C
- Freezer: -25 °C to -5 °C

- ➔ Confirm selection with **SET 7** control field.

5.4.2 Setting time (RTC)

① *Setting the time is only possible if RTC is activated in the installer menu (Parameter H68 = yes. See Section 8.8 "Real-time clock (RTC)" on page 19).*

- ➔ Deactivate control field lock: press any control field for at least 2 seconds.

Signal sounds and confirmation LED of the control field lights up.

- ➔ Press **SET 7** control field briefly.

Display shows *SEt*.

- ➔ Select parameter rtc in the user menu.

- ➔ Press **SET 7** control field.

DAY appears in the display.

To set the days of the week:

- ➔ Press **SET 7** control field again.

- ➔ Set day of the week.

- 0 = Sunday
- 1 = Monday ... 6 = Saturday

- ➔ Confirm selection with **SET 7** control field.

To set time (hour):

- ➔ Select time (h) using **Up 3** control field.

- ➔ Confirm selection with **SET 7** control field.

- ➔ Set hour.

- 0 - 23 hours

- ➔ Confirm selection with **SET 7** control field.

To set time (minute):

- ➔ Select time (‘) using **Up 3** control field.
- ➔ Confirm selection with **SET 7** control field.
- ➔ Set minutes.
 - 0 - 59 minutes
- ➔ Confirm selection with **SET 7** control field.

Display		Description	min.	max.
rtc				
	DAY	Day of the week 0 = Sunday 1 = Monday ... 6 = Saturday	0	6
	h	Time (hour)	0	23
	‘	Time (minute)	0	59

5.4.3 Display current temperature

- ➔ Deactivate control field lock: press any control field for at least 2 seconds.

Signal sounds and confirmation LED of the control field lights up.

- ➔ Press **SET 7** control field briefly.

Display shows *SEt*.

- ➔ Select parameter Pb1 in the user menu.
- ➔ Press **SET 7** control field.

Cold room temperature is displayed.

- ⓘ *Cold room temperature is identical with standard display.*

- ➔ Select parameter Pb2 in the user menu.
- ➔ Press **SET 7** control field.

Evaporator temperature is displayed

- ➔ Select parameter Pb3 in the user menu.
- ➔ Press **SET 7** control field.

Condenser temperature is displayed.

Display	Description	Unit
Pb1	Display of cold room temperature	°C
Pb2	Display of evaporator temperature	°C
Pb3	Display of condenser temperature	°C

5.4.4 Display alarm list

- ➔ Deactivate control field lock: press any control field for at least 2 seconds.

Signal sounds and confirmation LED of the control field lights up.

- ➔ Press **SET 7** control field briefly.

Display shows *SEt*.

- ➔ Select parameter AL in the user menu.
- ➔ Press **SET 7** control field.

Alarm list is displayed.

- ➔ Scroll through the alarm messages using **Up 3** or **Down 4** control fields

- ➔ Meanings of the abbreviations of the alarm messages See Section 6 “Alarm messages” on page 14.

5.5 Installer menu

To access the installer menu:

- ➔ Deactivate control field lock: press any control field for at least 2 seconds.

Signal sounds and confirmation LED of the control field lights up.

- ➔ Press **SET 7** control field for at least 5 seconds.
- PA1 (password entry) appears in the display.

- ➔ Press **SET 7** control field.
- ➔ Enter password using **Up 3** or **Down 4**.

- Password: **22**

- ➔ Confirm selection with **SET 7** control field.

To scroll in the installer menu:

- ➔ Scroll through the parameters using **Up 3** or **Down 4** control fields

- ⓘ *The parameter SP1 (set required temperature) is identical to the parameter SEt of the user menu (See Section 5.4.1 “Setting required temperature” on page 10).*

- ⓘ *Enter changed parameters in the parameter list.*

5.5.1 Set types of defrosting

- ① *Follow the parameter list for all defrosting settings.*
- ➔ Deactivate control field lock: press any control field for at least 2 seconds.

Signal sounds and confirmation LED of the control field lights up.

- ➔ Press **SET 7** control field for at least 5 seconds.
- PA1 (password entry) appears in the display.
- ➔ Press **SET 7** control field.
 - ➔ Enter password using **Up 3** or **Down 4**.
 - Password: **22**
 - ➔ Confirm selection with **SET 7** control field.
 - ➔ Select parameter *dCt* in the installer menu.

Types of defrosting

- 0 = Deactivate defrosting
 - 1 = According to cycle time (*dit*), depending on run time of compressor
 - 2 = According to cycle time (*dit*), independent of run time of compressor
 - 3 = Compressor shut down; defrosting after each shutdown of compressor
 - 4 = According to real time (RTC), See Section “5.5.6 Activating time (RTC) for defrosting” on page 13
- ➔ Confirm selection with **SET 7** control field.
 - ➔ Select type of defrosting.

5.5.2 Manual defrosting

- ➔ Press **Manual defrosting 2** control field for at least 5 seconds to start or stop manual defrosting.

During defrosting, the display shows the last measured cold room temperature immediately before the defrosting.

- ① *If the evaporator temperature is higher than the temperature set in parameter *dS1*, the display will flash 3x. No defrosting will take place.*

5.5.3 Periodic defrosting

- ① *It is possible when defrosting according to RTC to defrost periodically.*
- ① *When periodically defrosting using the parameters *dPH*, *dPn*, and *dPd*, it is possible to set the time as well as the interval for when defrosting should take place (e.g., once daily, every 2 days).*
- ① *Periodic defrosting possible maximum once a day.*
- ① *Periodic defrosting is usable exclusively when RTC is activated and set.*

To activate periodic defrosting:

- ➔ Deactivate control field lock: press any control field for at least 2 seconds.

Signal sounds and confirmation LED of the control field lights up.

- ➔ Press **SET 7** control field for at least 5 seconds.
- PA1 (password entry) appears in the display.
- ➔ Press **SET 7** control field.
 - ➔ Enter password using **Up 3** or **Down 4**.
 - Password: **22**
 - ➔ Confirm selection with **SET 7** control field.
 - ➔ Set the time (hours) (*dPH*): 0 to 23 hours, 24 = deactivated
 - ➔ Set the time (minutes) (*dPn*): 0 to 59 minutes
 - ➔ Set the defrosting interval (*dPd*): 1 = every day, 2 = every other day, etc.

5.5.4 Defrosting according to time lines

- ① *It is possible when defrosting according to RTC to defrost according to time lines.*
- ① *It is possible when defrosting according to time lines to defrost several times daily. Working days are differentiated from holidays.*

To activate defrosting:

- ➔ Deactivate control field lock: press any control field for at least 2 seconds.

Signal sounds and confirmation LED of the control field lights up.

- ➔ Press **SET 7** control field for at least 5 seconds.
- PA1 (password entry) appears in the display.
- ➔ Press **SET 7** control field.
 - ➔ Enter password using **Up 3** or **Down 4**.
 - Password: **22**
 - ➔ Confirm selection with **SET 7** control field.
 - ➔ Select parameter *dCt* operating mode defrosting in the installer menu.
 - ➔ Confirm selection with **SET 7** control field.
 - ➔ Select value 4 using the **Up 3** or **Down 4** control fields.
 - ➔ Select *Fd1* to define 1st holiday (See Section “8 List of Parameters” on page 16)
 - ➔ Select *Fd2* to define 2nd holiday (See Section “8 List of Parameters” on page 16)
 - ➔ Select *d1H* to *d6n* to define defrosting times on workdays (See Section “8 List of Parameters” on page 16)
 - ➔ Select *F1H* to *F6n* to define defrosting times on holidays (See Section “8 List of Parameters” on page 16)
 - ➔ Confirm selection with **SET 7** control field.

5.5.5 Adjusting humidity

- ① *It is possible to affect the humidity in the cold room using the evaporator fan operating mode.*
- ➔ Deactivate control field lock: press any control field for at least 2 seconds.

Signal sounds and confirmation LED of the control field lights up.

- ➔ Press **SET 7** control field for at least 5 seconds. PA1 (password entry) appears in the display.
- ➔ Press **SET 7** control field.
- ➔ Enter password using **Up 3** or **Down 4**.
 - Password: **22**
- ➔ Confirm selection with **SET 7** control field.
- ➔ Select parameter *FCO* in the installer menu.
- ➔ Confirm selection with **SET 7** control field.
- ➔ Set humidity.
 - Value 0: Fan runs together with condenser: low relative humidity.
 - Value 1: Fan also runs during clock breaks of the condenser: high relative humidity.

5.5.6 Activating time (RTC) for defrosting

- ① *Serves to set defrosting according to defined times.*

To activate RTC:

- ➔ Deactivate control field lock: press any control field for at least 2 seconds.

Signal sounds and confirmation LED of the control field lights up.

- ➔ Press **SET 7** control field for at least 5 seconds. PA1 (password entry) appears in the display.
- ➔ Press **SET 7** control field.
- ➔ Enter password using **Up 3** or **Down 4**.
 - Password: **22**
- ➔ Confirm selection with **SET 7** control field.
- ➔ Select parameter *H68* in the installer menu.
- ➔ Confirm selection with **SET 7** control field.
- ➔ Using the **Up 3** or **Down 4** control fields, set the value YES.
- ➔ Select parameter *dCt* in the installer menu.
- ➔ Confirm selection with **SET 7** control field.
- ➔ Set value 4 and confirm with **SET 7** control field.
- ➔ Confirm selection with **SET 7** control field.
- ➔ To set day of the week and time, See Section "5.4.2 Setting time (RTC)" on page 10.

To deactivate RTC (time):

- ➔ Select parameter *H68* in the installer menu.

- ➔ Confirm selection with **SET 7** control field.
- ➔ Using the **Up 3** or **Down 4** control fields, set the value no.
- ➔ Confirm selection with **SET 7** control field.

5.5.7 Activating door contact switch

If door contact switch is installed, set as follows:

- ➔ Deactivate control field lock: press any control field for at least 2 seconds.

Signal sounds and confirmation LED of the control field lights up.

- ➔ Press **SET 7** control field for at least 5 seconds. PA1 (password entry) appears in the display.
- ➔ Press **SET 7** control field.
- ➔ Enter password using **Up 3** or **Down 4**.
 - Password: **22**
- ➔ Confirm selection with **SET 7** control field.
- ➔ Select parameter *H17* in the installer menu.
- ➔ Confirm selection with **SET 7** control field.
- ➔ Set value 1 and confirm with **SET 7** control field.

Additional setting options:

- ➔ Parameter *tDO*: Delay until alarm is activated (standard delay: 1 minute)
- ➔ Parameter *dFO*: Delay until evaporator fan is switched off (standard delay: 0 minutes)
- ➔ Parameter *dCO*: Delay until condenser is switched off (standard delay: 1 minute)

5.5.8 Protecting the control against

- ① *It is possible to block the control against unauthorized access. Defrosting and stand-by function are locked but access to the installer menu and required temperature display continue to be possible.*

To lock user entries:

- ➔ Deactivate control field lock: press any control field for at least 2 seconds.

Signal sounds and confirmation LED of the control field lights up.

- ➔ Press **SET 7** control field for at least 5 seconds. PA1 (password entry) appears in the display.
- ➔ Press **SET 7** control field.
- ➔ Enter password using **Up 3** or **Down 4**.
 - Password: **22**
- ➔ Confirm selection with **SET 7** control field.
- ➔ Select parameter *LOC* in the installer menu.
- ➔ Confirm selection with **SET 7** control field.

- ➔ Using the **Up 3** or **Down 4** control fields, set the value **YES**.
- ➔ Confirm selection with **SET 7** control field.

To unlock user entries:

- ➔ Select parameter *LOC* in the installer menu.
- ➔ Confirm selection with **SET 7** control field.
- ➔ Using the **Up 3** or **Down 4** control fields, set the value **no**.
- ➔ Confirm selection with **SET 7** control field.

5.5.9 Reset to factory settings

- ① *It is possible if necessary to reset all parameters to the factory settings.*
- ➔ Disconnect unit briefly from the power supply.

- ➔ Start unit.
- ➔ After restarting and within 30 seconds, press any control field for at least 2 seconds.

Contact protection is canceled.

- ➔ Press **SET 7** and **Down 4** contact fields at the same time for at least 5 seconds.

Display shows *AP1*.

- ➔ Confirm selection with **SET 7** control field.

RUN appears in the display.

- ① *Display shows **YES** after successful reset.*

-or-

- ① *Display shows **no** after failed reset.*

The standard display appears.

6 Alarm messages

- ① *Alarm messages are automatically acknowledged as soon as the cause of the malfunction is resolved. Sole exception: High pressure fault (depending on setting of the parameters *PEn* and *PEi*). In this case, acknowledge parameter *rAP* as required.*

- ➔ To see alarm list, See Section “5.4.4 Display alarm list” on page 11.

Display	Meaning	Cause	Impact	Troubleshooting
E1	Room sensor defective	Measurement of values outside of operating range Sensor open/short-circuited/defective	Control of the unit with the help of parameters <i>Ont</i> and <i>OFt</i>	➔ Check sensor cable. ➔ Replace sensor.
E2	Evaporator package sensor defective	Measurement of values outside of operating range Sensor open/short-circuited/defective	Control of evaporator fan subject to compressor Maximum duration of defrosting	➔ Check sensor cable. ➔ Replace sensor.
E3	Condenser sensor defective	Measurement of values outside of operating range Sensor open/short-circuited/defective	Condenser fan rotates at full speed	➔ Check sensor cable. ➔ Replace sensor.
AH1	High temperature alarm	Room temperature higher than <i>SP1 + HA1</i> after the time <i>tA1</i>	None	➔ Ensure that the room temperature falls below <i>SP1 + HA1 - AFd</i> value.
AL1	Low temperature alarm	Room temperature lower than <i>SP1 + LA1</i> after the time <i>tA1</i>	None	➔ Ensure that the room temperature stays above <i>SP1 + LA1 + AFd</i> value.
OPd	Door alarm	Door is open longer than specified in <i>tdO</i> .	Compressor and evaporator fan are switched off as per parameters <i>dCO</i> and <i>dFO</i> .	➔ Close door.

Display	Meaning	Cause	Impact	Troubleshooting
Ad2	End of defrosting due to timeout	Defrosting terminated by timeout, parameter <i>dE1</i> , not by reaching the defrosting final temperature, parameter <i>dS1</i>	None	<ul style="list-style-type: none"> ➤ Wait for next defrosting. ➤ Set <i>dAt</i> = 0 (NO) to suppress the message in the future.
nPA	Hot gas thermostat switch	<p>Hot gas temperature too high</p> <p>Possible causes:</p> <p>Ambient temperature too high</p> <p>Condenser fan not running</p> <p>Condenser heavily soiled</p> <p>Compressor is defective</p>	Cooling mode has been interrupted	<ul style="list-style-type: none"> ➤ Lower ambient temperature. ➤ Clean condenser ➤ Check whether the condenser fan is rotating.
LPA	Low pressure fault	<p>Low pressure pressostat is activated</p> <p>Possible causes:</p> <p>Insufficient airflow in evaporator</p> <p>Faulty evaporator fan</p> <p>Evaporator is always iced</p> <p>Frozen drain pipe</p> <p>Obstructed refrigerant filter (different inlet and outlet temperatures)</p> <p>Lack of refrigerant (leakage)</p> <p>Too low condensation pressure</p> <p>Faulty expansion valve</p>	<p>Cooling mode has been interrupted</p> <p>Cooling mode is later continued when:</p> <p>Low pressure fault is no longer present</p> <p>maximum number of permissible low pressure faults (<i>PE_n</i>) has not yet been reached</p>	<ul style="list-style-type: none"> ➤ Clean air intakes ➤ Repair or replace ➤ Check defrost and defrost parameters. Increase defrost frequency ➤ Check drain heater and replace if necessary (for low temperature units) ➤ Change refrigerant filter ➤ Repair leakage, replace refrigerant load ➤ Too low ambient temperature, too high airflow rate, check and adjust condensation parameters (only for split units) or replace the unit ➤ Check possible humidity inside the circuit
HPA	High pressure fault	<p>High pressure pressostat is activated</p> <p>Possible causes:</p> <p>Ambient temperature too high</p> <p>Condenser fan not running</p> <p>Condenser heavily soiled</p>	<p>Cooling mode has been interrupted</p> <p>Cooling mode is later continued when:</p> <p>High pressure fault is no longer present</p> <p>maximum number of permissible high pressure faults (<i>PE_n</i>) has not yet been reached</p>	<ul style="list-style-type: none"> ➤ Acknowledge fault or restart Unit. ➤ Lower ambient temperature. ➤ Clean condenser ➤ Check whether the condenser fan is rotating.

7 Diagrams

7.1 Switch hysteresis principle – evaporator fan

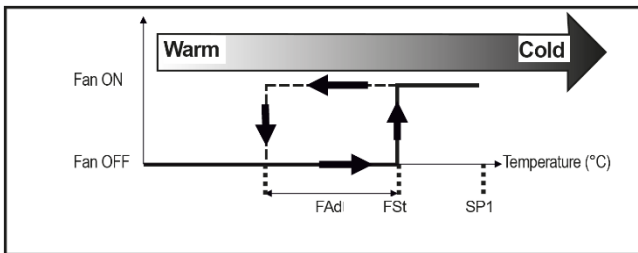

Figure 2: Switch hysteresis principle – evaporator fan

- $SP1$ = Required temperature
- FSt = Switching threshold – evaporator fan (evaporator temperature)
- FAd = Switch hysteresis – evaporator fan
- Switch-on point: FSt
- Switch-off point $FSt + FAd$
 - Example: $SP1 = 0\text{ °C}$; $FSt = 5\text{ °C}$;
 $FAd = 20\text{ K}$
 - Cooling of the refrigeration cell: Fan switches on at 5 °C (evaporator temperature)
 - Warming of the refrigeration cell: Fan switches off at 25 °C (evaporator temperature)

7.2 Hysteresis temperature alarm

- Example: $SP1 = 0\text{ °C}$, $HA1 = 10\text{ K}$, $LA1 = -5\text{ K}$, $AFd = 4\text{ K}$, $tA1 = 60\text{ min}$
- When the cold room temperature of $SP1 + HA1$, thus 10 °C , is exceeded, the high temperature alarm is activated after the time $tA1$ (1 hour).
- When the cold room temperature falls below $SP1 + HA1 - AFd$, thus 6 °C , the alarm is canceled.
- When the cold room temperature falls below $SP1 + LA1$ ($LA1$ negative), thus -5 °C , the low temperature alarm is activated after the time $tA1$ (1 hour).

When the cold room temperature exceeds $SP1 + LA1 + AFd$, thus -1 °C , the alarm is canceled.

8 List of Parameters

NOTE!	<p>Property damage due to lack of specialist knowledge!</p> <p>► Ensure that only trained qualified personnel operate the control.</p>
-------	---

① Opening and dealing with the list or parameters is described in Section “5.5 Installer menu” on page 11.

Display	Description	Unit	min.	max.	Freezer (TK) set point value	Standard refrigeration (NK) set point value	Modified parameter value
8.1 Setting target temperature							
SP1	Required temperature NK	°C	-5 °C	15 °C		0	
	Required temperature TK	°C	-25 °C	-5 °C	-20		
dF1	Switch hysteresis (≠ 0)	K	-58	302	2	2	
8.2 Compressor run time							
Ont	Compressor run time with a defective room temperature sensor	Min	0	250	10	10	
Oft	Compressor downtime with defective room temperature sensor	Min	0	250	5	5	
dOF	Minimum downtime, compressor (compressor protection)	Min	0	250	4	4	

Display	Description	Unit	min.	max.	Freezer (TK) set point value	Standard refrigeration (NK) set point value	Modified parameter value
OdO	Compressor downtime after switching on the unit	Min	0	250	1	1	
Pot	Pump out time	Sec	0	250	0	0	
8.3 Defrosting							
dit	Defrosting cycle [h] ① <i>If there is too much icing, the defrost cycle can be reduced.</i>	Hour	0	250	2	2	
dCT	Defrosting operating mode0 = Defrosting deactivated 1 = According to cycle time (<i>dit</i>), depending on run time of the compressor 2 = According to cycle time (<i>dit</i>), independent of run time of the compressor 3 = Compressor shut down; defrosting after each shutdown of the compressor 4 = According to real time clock (RTC), Parameter <i>H68</i> = 1		0	5	2	2	
dE1	Maximum duration of defrosting (timeout)	Min	1	250	60	60	
dS1	Defrosting final temperature	°C	-58	302	20	20	
PrH	Preheating time trace heating	Min	0	255	0	0	
dPH*	Start of periodic defrosting: Hour 24 = deactivated	Hour	0	24	24	24	
dPn*	Start of periodic defrosting: Minute	Min	0	59	0	0	
dPd*	Defrosting interval of periodic defrosting: Days	Days	1	7	1	1	
Fd1*	Select 1st holiday 0 = Sunday, 1 = Monday to 6 = Saturday; 7 = deactivated		0	7	0	0	
Fd2*	Select 2nd holiday 0 = Sunday, 1 = Monday to 6 = Saturday; 7 = deactivated		0	7	7	7	
d1H*	Start defrosting 1 on a workday: Hour 24 = deactivated	Hour	0	24	7	7	
d1n*	Start defrosting 1 on a workday: Minute	Min	0	59	0	0	
d2H*	Start defrosting 2 on a workday: Hour 24 = deactivated	Hour	d1H	24	21	21	
d2n*	Start defrosting 2 on a workday: Minute	Min	0	59	0	0	
d3H*	Start defrosting 3 on a workday: Hour 24 = deactivated	Hour	d2H	24	24	24	
d3n*	Start defrosting 3 on a workday: Minute	Min	0	59	0	0	
d4H*	Start defrosting 4 on a workday: Hour 24 = deactivated	Hour	d3H	24	24	24	
d4n*	Start defrosting 4 on a workday: Minute	Min	0	59	0	0	
d5H*	Start defrosting 5 on a workday: Hour 24 = deactivated	Hour	d4H	24	24	24	
d5n*	Start defrosting 5 on a workday: Minute	Min	0	59	0	0	

Display	Description	Unit	min.	max.	Freezer (TK) set point value	Standard refrigeration (NK) set point value	Modified parameter value
d6H*	Start defrosting 6 on a workday: Hour 24 = deactivated	Hour	d5H	24	24	24	
d6n*	Start defrosting 6 on a workday: Minute	Min	0	59	0	0	
F1H*	Start defrosting 1 on a holiday: Hour 24 = deactivated	Hour	0	24	12	12	
F1n*	Start defrosting 1 on a holiday: Minute	Min	0	59	0	0	
F2H*	Start defrosting 2 on a holiday: Hour 24 = deactivated	Hour	F1H	24	23	23	
F2n*	Start defrosting 2 on a holiday: Minute	Min	0	59	0	0	
F3H*	Start defrosting 3 on a holiday: Hour 24 = deactivated	Hour	F2H	24	24	24	
F3n*	Start defrosting 3 on a holiday: Minute	Min	0	59	0	0	
F4H*	Start defrosting 4 on a holiday: Hour 24 = deactivated	Hour	F3H	24	24	24	
F4n*	Start defrosting 4 on a holiday: Minute	Min	0	59	0	0	
F5H*	Start defrosting 6 on a holiday: Hour 24 = deactivated	Hour	F4H	24	24	24	
F5n*	Start defrosting 5 on a holiday: Minute	Min	0	59	0	0	
F6H*	Start defrosting 5 on a holiday: Hour 24 = deactivated	Hour	F5H	24	24	24	
F6n*	Start defrosting 6 on a holiday: Minute	Min	0	59	0	0	
8.4 Evaporator fan							
FSt	Switching threshold – evaporator fan (evaporator temperature)	°C	-58	302	0	10	
FAd	Switch hysteresis – evaporator fan: <i>FSt + FAd</i>	K	0.1	25	2	2	
Fdt	Minimum downtime for evaporator fan after defrosting Includes drip-off time <i>dt</i>	Min	0	250	4	4	
dt	Drip-off time after a defrosting	Min	0	250	3	3	
FCO	Operating mode evaporator fan 0 = Fan runs together with compressor (low relative humidity) 1 = fan runs continuously (high relative humidity)		0	1	0	0	
FdC	Switch-off delay evaporator fan after switching off the compressor (using the remaining cold in the evaporator unit)	Min	0	250	0	0	
8.5 Alarms and times							
Afd	Hysteresis temperature alarm: <i>SP1 + HA1 - AFd; SP1 + LA1 + AFd</i>	K	0.1	25	4	4	
HA1	Upper alarm temperature: <i>SP1 + HA1</i>	K	LA1	302	5	5	
LA1	Lower alarm temperature <i>SP1 + LA1</i>	K	-58	HA1	-5	-5	
PAO	Blocking time of temperature alarms after switching on the unit	Hour	0	10	1	1	
dAO	Blocking time of temperature alarms after defrosting	Min	0	250	30	30	
tdO	Time delay of alarm, door open	Min	0	250	15	15	
tA1	Delay of temperature alarm	Min	0	250	0	0	
dAt	Select whether end of defrosting due to timeout (<i>dE1</i>) is alarm condition: 0 (no) = no alarm 1 (YES) = alarm		0	1	1	1	
dCO	Switch-off delay for compressor when door	Min	0	250	15	15	

Display	Description	Unit	min.	max.	Freezer (TK) set point value	Standard refrigeration (NK) set point value	Modified parameter value
	is open						
dFO	Switch-off delay for evaporator fan when door is open	Min	0	250	15	15	
PEn	Maximum number of high pressure faults within the time <i>PEi</i> until the fault must be acknowledged by the user	Number	0	15	8	8	
PEi	Time interval within which the number of high pressure faults defined in PEn has to occur before acknowledgment by the user is required	Min	1	250	60	60	
8.6 Condenser fan							
LOC	Locking user entries: <ul style="list-style-type: none"> ▪ 0 (no) = control fields not locked ▪ 1 (YES) = control fields locked 		0	1	0	0	
CA1	Offset room temperature sensor	K	-30	30	0	0	
CA2	Offset evaporator temperature sensor	K	-30	30	0	0	
CA3	Offset condenser temperature sensor	K	-30	30	0	0	
8.7 Door contact switch							
H17	Select door contact switch 0 = Without door contact switch 1 = With door contact switch		0	1	0	0	
8.8 Real-time clock (RTC)							
H68	Real-time clock (RTC) no = RTC is missing YES = RTC is present		no	YES	no	no	
8.9 Manual defrosting							
dEF	Start manual defrosting <i>① Same function as Manual defrosting 2 control field</i>						
8.10 Other parameters							
Aon/AoF	No function						
ddd	Selects type of value to display SP1 (0) = setpoint Pb1 (1) = will use probe Pb1 Pb2 (2) = will use probe Pb2 Pb3 (3) = will use probe Pb3 Pb4 (4) = will use probe Pb4 Pb5 (5) = will use probe Pb5 Pbi (6) = will use the virtual probe LP (7) = will use the probe of the LINK ² network	Number	0	7	1	1	
rAP	Acknowledge high pressure fault: contact service if the fault occurs repeatedly.						
OFF	Switch device to stand-by <i>① Same function as Stand-by 5 control field</i>						

* Only visible when *dct* = 4 or 5

Belgien
froid.viessmann.be

Dänemark
koele.viessmann.dk

Deutschland
kuehlen.viessmann.de

Estland
kylm.viessmann.ee

Finnland
kylma.viessmann.fi

Frankreich
froid.viessmann.fr

Irland
cooling.viessmann.co.uk

Lettland
cooling.viessmann.com

Litauen
saldymas.viessmann.lt

Niederlande
koelen.viessmann.nl

Norwegen
kjol.viessmann.no

Österreich
kuehlen.viessmann.at

Polen
chlodnicze.viessmann.pl

Russland
holod.viessmann.ru

Schweden
kyla.viessmann.se

Schweiz
kuehlen.viessmann.ch

Spanien
refrigeracion.viessmann.es

Vereinigtes Königreich
cooling.viessmann.co.uk