

Range + Convection oven Metos Ardox S6/Chef 240 400V3N

Flat-top range with six 3,5 kW cooking zones. Chrome-steel top, construction stainless steel

- chrome on the cooking top reduces heat loss
- stepless power regulator
- flat cooking top is easy to clean

Stand with Metos Chef 240 convection oven:

- cooking cabinet, door and external surfaces stainless steel
- temperature: +50-300°C
- timer 0-120 min or continuous
- manual valve for taking out the humidity from the cabinet
- manual humidification, also with continuous humidification: when requested, humidification level can be changed
- 2 removable pairs of rails for 2 x GN2/1



Range + Convection oven Metos Ardox S6/Chef 240 400V3N

Product capacity	6 cooking zones, oven 2xGN2/1
Capacity	1200x800x900
Item width mm	1200
Item depth mm	800
Item height mm	900
Package volume	1.17
Unit of volume	m3
Package volume	1.17 m3
Package length	130
Package width	90
Package height	100
Package unit of dimension	cm
Package dimensions (LxWxH)	130x90x100 cm
Net weight	201
Net weight	201 kg
Gross weight	273
Package weight	273 kg
Unit of weight	kg
Connection power kW	28.5
Fuse Size A	50
Connection voltage V	400/230
Number of phases	3NPE
Frequency Hz	50
Startup current A	41.5
Protection rating (IP)	X3
Type of electrical connection	Semifixed
Electrical conn. height mm	250
Remarks (electrical)	Working current 41A
Cold water diam.	3/4"

Range + Convection oven Metos Ardox S6/Chef 240 400V3N

Power type	electric
Raw material	Stainless steel
Type	electric
Operation type	electromechanical
Temperature area °C	50-300
Top material type	chrome
Cooking zone	6
Cooking zone power kW	3.5
Power range kW	28.5
Frying top type	smooth



METOS ARDOX

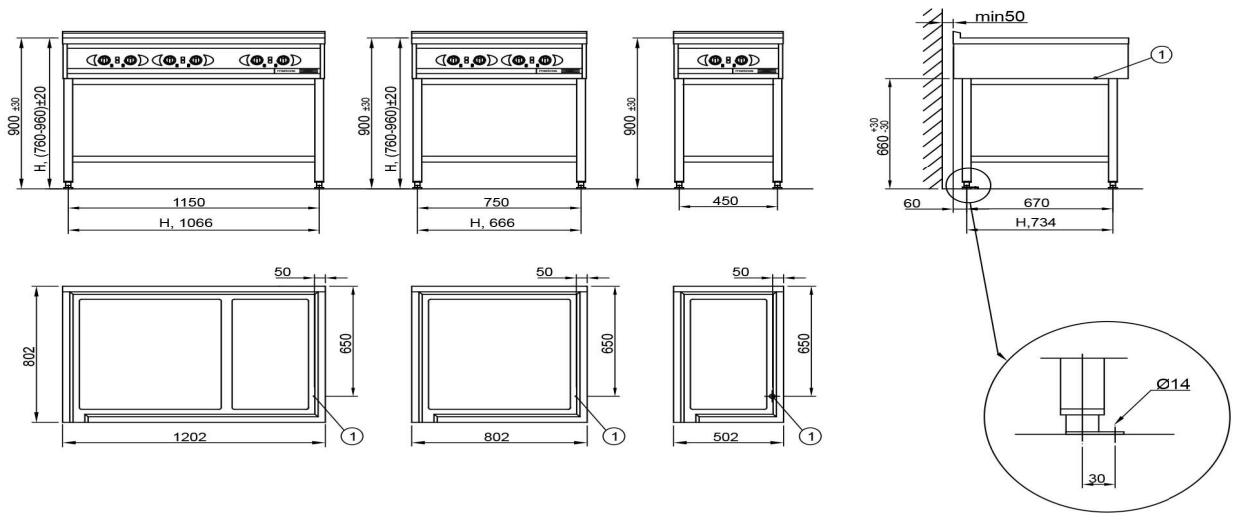
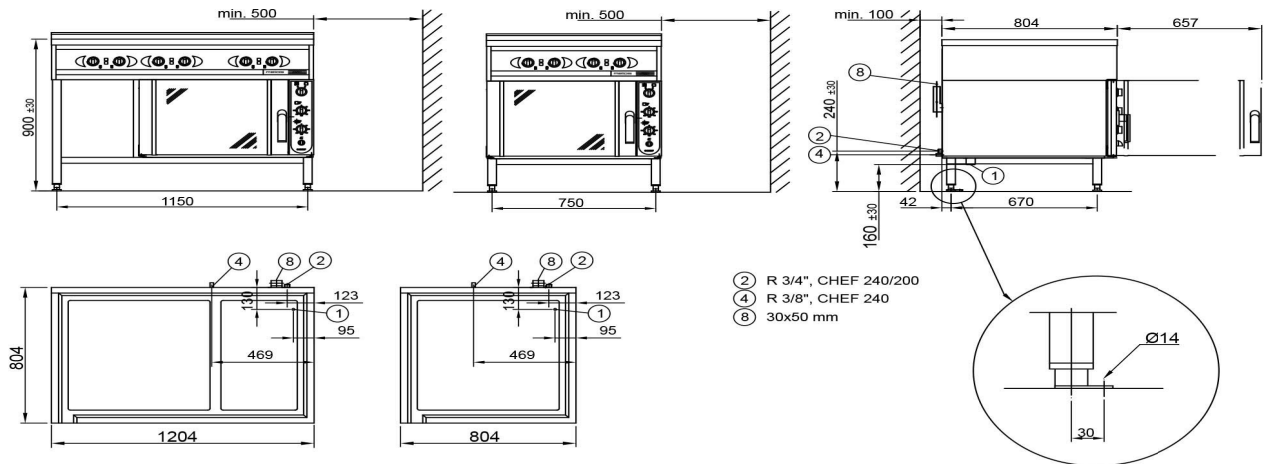

METOS ARDOX TABLETOP

