

Mixer Metos Bear AR80 VL-1 with manual control

Powerful but quiet motor, stepless speed control, unique bowl clamping system and digital timer makes this manual controlled Metos Bear AR80 VL-1 mixer an incomparable kitchen help.

The bowl lifting and lowering and also stepless speed control are controlled by the levers that located on the right side of the machine. The bowl lowering with gas dampers provides a soft bowl lowering and improved ergonomics. The variable speed system ensures the mixer processes all ingredients optimally.

The Metos Bear AR80 VL-1 mixer features a unique clamping system. The bowl is placed between the bowl arms that lifts the bowl into place and automatically raises it to the correct working height.

The capacity of Metos Bear AR80 VL-1 for 80 liter bowl; 50 kg bread dough 50%, 50 kg mashed potatoes, 30 liter whipped cream.

The transparent safety guard protects against dust and also prevents the flour dusting to the room. The safety guard has an integrated filling chute. The guard can be removed without any mechanical fittings.

A control panel has a smooth uniform surface with recessed buttons and rubber sealing for improved hygiene. The machine body is made of powder coated steel which makes it easy to clean. The bowl, beater and hook are made of stainless steel and are therefore dishwasher safe.

The stainless steel scraper, which is available as an optional accessory, is equipped with non-stick blade. The scraper keeps the sides of the bowl clean and eliminates the need for manual scraping. Using the scraper you will increase



mixing volume and improve the utilization of the raw materials. A stop during whipping and mixing is totally unnecessary.

- Floor model
- Bowl 80 liter
- Stepless speed control, manual
- Manual bowl lifting and lowering
- Bowl lowering with gas damper
- Digital timer displaying minutes and seconds
- Plastic safety guard
- Belt driven
- White power coated machine body
- Emergency stop button

THE DELIVERY INCLUDES:

- Stainless steel bowl
- Aluminium whip with stainless steel wires
- Stainless steel beater
- Stainless steel hook

ACCESSORIES (to be ordered separately):

- B tools (bowl 30 liter, whip, beater, hook)
- Whip with reinforcement no. 44b
- Stainless steel whip no. 14
- Special stainless steel flat beater
- Scraper with holder for 80 liter bowl, scraper for 40 liter bowl
- Bowl trolleys for 80 and 40 liter bowls
- 1 mm reinforced whip for 40 liter bowl
- Tool rack mixing volume and improve the utilization of the raw materials. A stop during whipping and mixing is totally unnecessary.

- Floor model
- Bowl 80 liter
- Stepless speed control, manual
- Manual bowl lifting and lowering
- Bowl lowering with gas damper
- Digital timer displaying minutes and seconds
- Plastic safety guard
- Belt driven
- White power coated machine body
- Emergency stop button

THE DELIVERY INCLUDES:

- Stainless steel bowl
- Aluminium whip with stainless steel wires
- Stainless steel beater
- Stainless steel hook

ACCESSORIES (to be ordered separately):

- B tools (bowl 30 liter, whip, beater, hook)
- Whip with reinforcement no. 44b
- Stainless steel whip no. 14
- Special stainless steel flat beater

- Scraper with holder for 80 liter bowl, scraper for 40 liter bowl
- Bowl trolleys for 80 and 40 liter bowls
- 1 mm reinforced whip for 40 liter bowl
- Tool rack

Mixer Metos Bear AR80 VL-1 with manual control

Item width mm	710
Item depth mm	1155
Item height mm	1480
Package volume	1.896
Unit of volume	m3
Package volume	1.896 m3
Package length	84
Package width	124
Package height	182
Package unit of dimension	cm
Package dimensions (LxWxH)	84x124x182 cm
Net weight	289
Net weight	289 kg
Gross weight	332
Package weight	332 kg
Unit of weight	kg
Connection power kW	3
Fuse Size A	16
Connection voltage V	400
Number of phases	3NPE
Frequency Hz	50
Protection rating (IP)	32
Type of electrical connection	Semifixed
Cleaning	machine washable;hand wash
Power range kW	2.9
Bowl transfer	manual
Attachment drive	No
Timer	Yes
Speed rpm	257

Mixer Metos Bear AR80 VL-1 with manual control

User Manual SE



METOS KARHU / BEAR

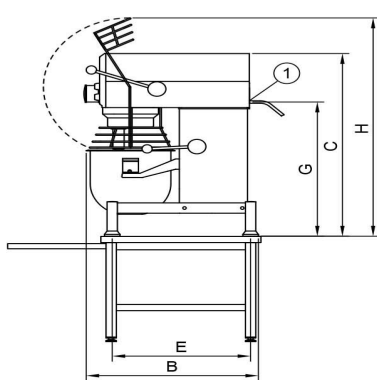

RN 10/20 TABLE

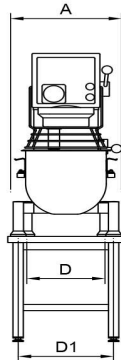

RN 10/20

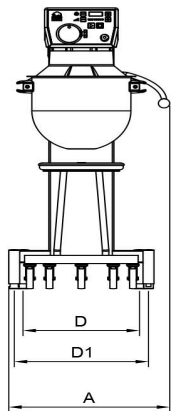
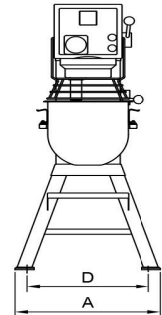
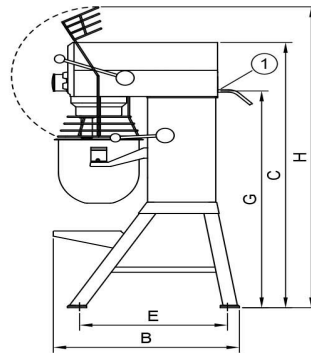

KODIAK

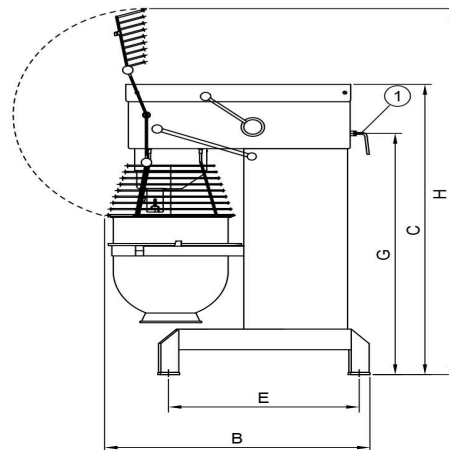
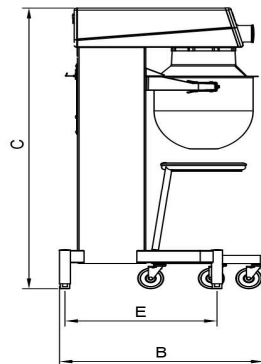

AR 30-AR 100

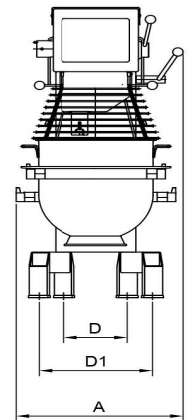

Metos	A	B	C	D	D1	E	G	H
RN 10 TABLE	369	592	639	235	329	505		869
RN 20 TABLE	430	675	885	303	370	535	651	1058
RN 10	548	606	1180	479	479	518		1495
RN 20	566	720	1286	473	473	573	1032	1415
AR 30	520	910	1210	230	380	653	1015	1500
AR 40	535	910	1210	230	380	653	1015	1500
AR 60	648	1028	1413	245	440	739	1175	1780
AR 80	654	1150	1470	245	550	826	1154	1899
AR 100	691	1171	1593	243	570	824	1277	2021
KODIAK	623	792	1367	450	520	589		