

Vanndispenser, 1-Sidig

Kjølt Metos D-I Wd-E

Elektr. Vanntapp

Drop-in modell til å bygge inn i møbel. Effektiv og driftsikker kjølemaskin

- kapasitet 60ltr/time
- elektronisk tappekran
- avløp i toppen
- leveranse inkluderer ikke forbindelse fra kjølemaskin til tappekran



Vanndispenser, 1-Sidig Kjølt Metos D-I Wd-E Elektr.Vanntapp

Produktkapacitet	60 liter / timme
Bredde mm	330
Dyp mm	400
Høyde mm	15
Pakkevolum inkl. emballasje	0,11
Volumenhet	m ³
Pakkevolum	0,11 m ³
Lengde på forpakning	50
Bredde på forpakning	55
Høyde på forpakning	40
Forpakkingsstørrelse	cm
Transport mål (LxDxH)	50x55x40 cm
Netto vekt	29
Net weight with unit	29 kg
Bruttovekt	29
Vekt inkl. emballasje	29 kg
Vektenhet	kg
Tilkoblingseffekt kW	0,5
Sikringsstørrelse A	10
Spenning V	230
Antall faser	1NPE
Frekvens Hz	50/60
Maks strømforbruk A	2,2
Beskyttelsesgrad (IP)	43
Kabellengde mm	3200
Type elektrisk tilkobling	Stikkontakt
Elektrisk tilkobling	EL.kran,halvfast,1N,230V
Kaldt vann diam.	R1/2"
Kaldt vann, maks trykk kPa	500

Vanndispenser, 1-Sidig Kjølt Metos D-I Wd-E Elektr.Vanntapp

Avløp, diam.	R1/2"
Kjølemedie	R290
Mengde kjølemedie g	60

Installation on top of the table

Drop-in Water dispenser Metos D-IWD-E electronic

When constructing the counter, an opening for the connection cable must be considered. The opening must be at least the size of a plug (diameter min. 40 mm). In addition, the edges of the opening must be finished to make sure that the connection cable is not damaged by rubbing against the opening edge.

The counter, where drop-in units are installed, must be damp-proof and strong enough to bear the appliance weight.

Net weight:
D-IWD-E 29 kg

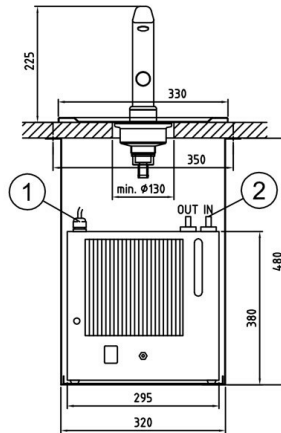

Cooling unit can also be set inside the buffet unit.
Make sure of good ventilation.

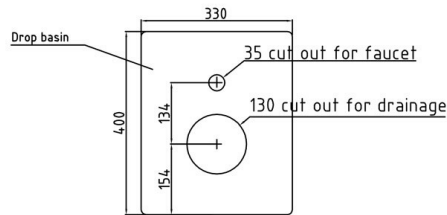
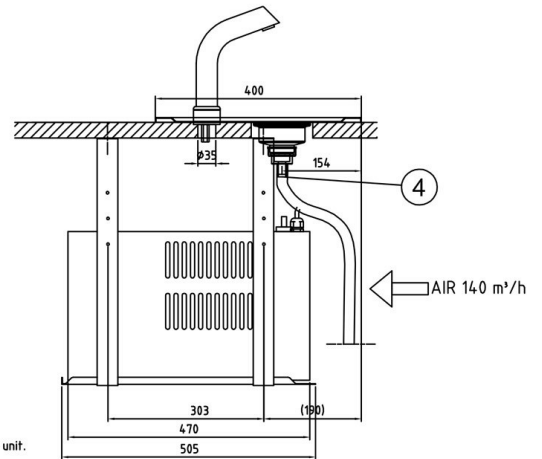

The holes to the table for
fastening the faucet and drainage.



The electrical box of the electronic faucet has to be fixed inside the counter. Please note the water connection which is connected to the electrical box.

- ① Electric connection: 230V, 1~, 0,5kW, 10A
The length of the connection cable is 3,2 m.
- ② Cold water connection: R1/2", max 500 kPa
- ④ Drain: Connection for hose with 18 mm inner diameter. Hose not included in the delivery.

This document may not be copied in part or in whole by any process nor passed on to a third party without the written permission of the owner Metos Oy Ab.